TECHNICAL GUIDE



CONTENTS

SECTION 1

- 03 PETRARCH OVERVIEW.
- 03 1.1 Features
- 03 1.2 Environment
- 04 1.3 Technical Data
- 05 1.4 Colours, Finishes & Formats
- 06 1.5 Petrarch Core & Surface
- 08 1.6 Petrarch - Service Life & Performance

SECTION 2

- 09 RAINSCREEN FAÇADE APPLICATION.

SECTION 3

- 11 PETRARCH RAINSCREEN SYSTEMS
- 12 3.1 Mechanical Secret Fix Application (Downer DCS004 Support System)
- 18 3.2 Adhesive Secret Fixing Application
- 21 3.3 Visible Fixing Application
 - 22 3.3.1 Rivets to metal subframe
 - 27 3.3.2 Screws to timber battens

SECTION 4

- 32 DETAILING/ACCESSORIES/DESIGN CONSIDERATIONS
- 32 4.1 Panel Joints
- 33 4.2 Corner Options
- 34 4.3 Signage; Lighting Fixments; General Attachments
- 34 4.4 Ventilation Gaps & Ground Clearance
- 35 4.5 Panel Perforations
- 36 4.6 Cavity Fire Barriers
- 36 4.7 Cavity Insulation

SECTION 5

- 37 PETRARCH GENERAL INFORMATION.
- 37 5.1 Delivery and Packaging
- 38 5.2 Site Handling
- 38 5.3 Storage
- 39 5.4 Workmanship
- 40 5.5 Petrarch Cleaning Instruction

SECTION 1

PETRARCH OVERVIEW

Petrarch is a versatile, reconstituted stone cladding solution, created primarily from natural by-product materials; such as stone and marble. A bespoke thermoset polymer and woven glass fibre rovings result in a panel with incredible strength, boasting an A2-s1,d0 reaction to fire rating (EN 13501).

Highly durable and impact resistant, it is considerably lighter than natural stone systems. Designed for perfection, this man-made alternative to stone cladding is extremely weather resistant - designed to withstand the most severe environmental conditions, and just like natural stone, Petrarch matures over time, giving character and depth to any architectural scheme.

Petrarch reconstituted stone panels are manufactured in the UK where the product has been supplied to the rainscreen industry for nearly 50 years. Thanks to a robust distribution network it also adorns buildings across the USA and throughout Europe.

1.1 Features

- BBA Approved
- Reaction to fire classification:
 - Petrarch A2 - A2-s1, d0 in accordance with BS EN 13501.
 - Petrarch - B-s2, d0 in accordance with BS EN 13501 (Available under request).
- Large scale fire tests on B-s2, d0 panels
 - BS: 8414-2:2005 meeting BR135:2013 Annex B performance criteria
 - NFPA 285
- Installation by mechanical secret fix, site adhesive and face fixing
- Mechanical secret fix and face fix systems CWCT Windload and Impact tested.
- Colours and textures emulate natural stone
- Colour matching service
- Extremely durable surface, easy to clean and maintain
- ISO 9001 & 14001 accredited
- Proven performance and life expectancy in excess of 30 years.

1.2 Environment

At Petrarch we are committed to our environmental promise and are ISO 14001:2015 certified.

As a company we are conscious of our environmental responsibility and recognise the potential environmental impact of our processes and products.

At all times we adhere to the latest environmental legislations and standards.

Additionally, we endeavour to maximise positive effects on the environment.

In all our activities we aim to:

- Promote the use of environmentally friendly processes and materials.
- Use only sustainable, natural resources where possible.
- Achieve continuing improvements in environmental performance, over and above regulatory and legislative requirements.
- Raise the awareness of environmental issues within our business.
- Where possible satisfy local needs using local resources.
- Develop and promote environmentally friendly products, processes and architectural solutions.

We make and supply a wide range of systems, all with varying levels of recycled content and differing environmental benefits.

Every effort is taken to minimise the amount of waste created during production. Off-cut Petrarch panels are transformed into samples and packaging wherever possible, whilst a small amount will be disposed of as general waste.

As a company we take our environmental responsibilities seriously, all employees are responsible for working towards our overall objectives.

1.3 Technical Data

Manufacturing Tolerances			
Thickness Tolerance	+ 1.5mm / -0.5mm	Due to Petrarch manufacturing process, average positive and negative thickness tolerance needs to be differentiated.	
Cutting Tolerance	± 1mm per 1m / ± 2mm max.		
Cut Edge	Untreated, saw marks might be visible Occasionally, edge chipping < 2mm from panel edge might occur due to board composition/manufacturing process.	Edge sealing not required	
Physical Properties			
Reaction to fire classification	Petrarch A2 A2-s1, d0 Petrarch B-s2, d0	EN13501-1:2007+A1:2009	Reaction to Fire
Façade fire performance	PASS	NFPA 285 (US) BS8414, assessed by BRE 135 (UK)	Large Scale test as part of a standard assembly Petrarch B-s2,d0
Flexural Strength	>25MPa	EN14617-2:2016	
Freeze-Thaw	No significant loss in performance	EN14617-5:2012	
Modulus of elasticity	>11,000 MPa		From flexural testing
Water Absorption	0.2% by weight		24hour total immersion
Impact Resistance	Category B 10mm - Soft & Hard Body Class 1 / Negligible Risk 7mm - Soft Body - Class 1 / Moderate Risk Hard Body - Class 1 / Negligible Risk	CWCT TN76	Category B - Readily accessible to the public and others with little incentive to exercise care. Chance of accident occurring and misuse.
Wind Load Resistance	2.4 kN/m ² - Serviceability 3.6 kN/m ² - Safety	CWCT Standard Test Methods for Building Envelopes 2005	
Cyclic Loading	2.4 kN/m ² - Serviceability	CWCT, based on BRE Digest 346, Part 7, which is compatible with BS 6399	Fatigue test representing typical UK service loads in 50-year exposure period
Linear coefficient of thermal expansion	22x10 ⁻⁶ / °C	BS 1902-Section 5.3:1990	
Density	2240 kg/m ³		
On site Tolerances			
Joint width	10mm		

1.4 Colours, Finishes & Formats

Colours

Petrarch is available in a wide range of standard colours with the ability to create custom colours in projects over 400m².



Standard finishes

Petrarch is available in four standard finishes



Smooth Standard
Flat surface



Smooth Matt
Shotblasted



Riven Standard
Slate like surface

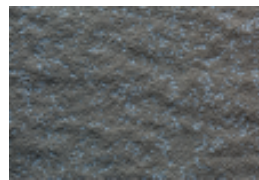

Riven Matt
Shotblasted

Smooth Finish (Non Directional)



2430 / 3040mm

Riven Finish (Directional)

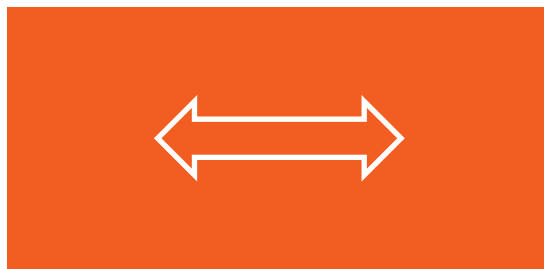

2430 / 3040mm

1210mm

Custom textures, etched patterns and a polish honed finish are also available upon request.



Formats

Sheet Sizes and Weight

Gross Size (mm)	Net Size (mm)*	Nominal Thickness (mm)	Nominal Weight (kg/m ²)
3048x1219	3040x1210	7	15.7
		10	22.0
2438x1219	2430x1210	7	15.7
		10	22.0

*Please note that Petrarch panels come off the production line untrimmed (rough edges) and trimming is required to square the panel. Maximum Net panel sizes 2430 x 1210 & 3040 x 1210mm. Further allowance of 3mm per cut. Honed is only available in 10mm thickness and with a maximum width of 989mm.

1.5 Petrarch Core & Surface

Petrarch is manufactured with a homogeneous reinforcement so the product will not delaminate and is immune to both insect and vermin attack. In addition, pressure moulded manufacturing process creates a high-density panel which is unaffected by freeze-thaw degradation due to a surface which is virtually non-porous with a water absorption ratio of less than 0.2% after a 24h immersion.

Manufacturing Process

Petrarch cladding boards are manufactured in our UK based factory in Hastings.

Each panel's unique colour recipe is weighed and mixed to create a malleable mixture that is poured onto a conveyor belt. The mixture then passes through a series of rollers, each with a specific and very important task to achieve an even surface while reducing the thickness. Once the required thickness is obtained, an automated mechanism activates, and the "blanket" is cut to the standard production length.

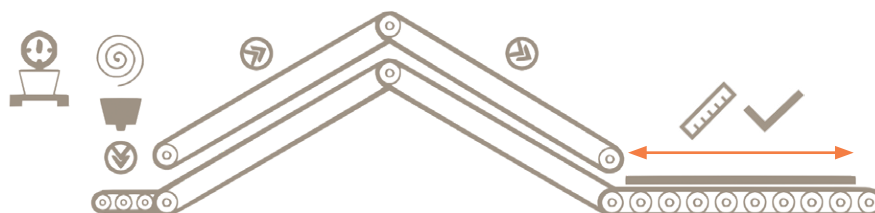

These "blankets" will then be transferred to a pressure chamber where a mould is applied under a specific temperature, pressure and time. The boards will come out of this process with rough edges but already with Petrarch intrinsic strength properties. In-house visual and mechanical tests will be carried out to ensure product quality.



The following steps are dependent on finish and fabrication required:

- Standard finish - edge trimming to square the panels up.
- Matt finish - shotblast process followed by edge trimming.

Following the above processes, Petrarch panels are ready for either in-house fabrication (cutting, drilling, etc.) or can be shipped out for on-site fabrication.

Surface characteristics

Petrarch's unique manufacturing process can create a pitted, or open texture, which can be seen on the face of the panel post pressing. The surface pattern on panels featuring a mix of different marble colours is also achieved during the manufacturing process. This will create completely random patterns meaning that there will be areas with a higher or lower density of each marble colour.

These nuances enhance its 'natural stone' aesthetic and does not affect its integrity.

Matt or honed finishes are achieved by removing the surface layer; exposing the core texture for a distinctive stone-like look.

Please note, these processes are not detrimental to the intrinsic qualities of the Petrarch panel.



Colour fastness / UV Resistance

Due to the manufacturing process of Petrarch there is always a small possibility that minor colour differences may occur between production batches. Good on-site practise is to ensure all panels on the same façade/ block/area come from the same batch and are ordered at the same time ideally.

After natural weathering, slight initial dulling of the surface and slight change in colour shade may occur, particularly on the dark coloured material and dependent on façade orientation and weather conditions. However, this process is not likely to be progressive.

Panels that have been shot blasted are much less likely to suffer from the effects of weathering.

Petrarch, as most materials do, will expand and contract with changes in the environment such as heat and moisture, it is important that the guidelines for fixed and sliding points are adhered to and that the horizontal and vertical joints between the panels are spaced as advised.

Surface Contamination

Most graffiti, paint or other substances can be easily removed.

For specific cleaning requirements please contact Petrarch who can provide more detailed advice on the surface maintenance.

Surface Coatings

Petrarch matt panels can be supplied with a range of factory applied coatings. These coatings can be used to provide exceptional anti-graffiti properties to the more vulnerable areas of the building, or simply to seal and enrich the stone like panel surface.

For further information on coating options please contact Petrarch who will be pleased to assist with any specific requirements.

1.6 Petrarch - Service Life & Performance

Petrarch panels durability and service life will depend upon the supporting structure and environment that the building is located in. The panels are highly resistant to the effects of natural exposure, climatic extremes, and atmospheric pollution, including exposure to industrial and saline atmospheres which do not appear to cause any structural deterioration.

As declared on Petrarch BBA certificate 21/5873, Petrarch panels are expected to have a service life in excess of 30 years.



SECTION 2

RAINSCREEN FAÇADE APPLICATION

Overview

Rainscreen cladding is a non-loadbearing external wall assembly comprising two layers. A protective outer skin of cladding panels and an insulated and airtight backing wall both separated by a ventilated cavity.

1. Load bearing support (SFS, concrete, masonry or timber studs)
2. Weather barrier
3. Support system
4. Insulation (refer to section 4.7)
5. Ventilated cavity - Airflow
6. Cladding panel

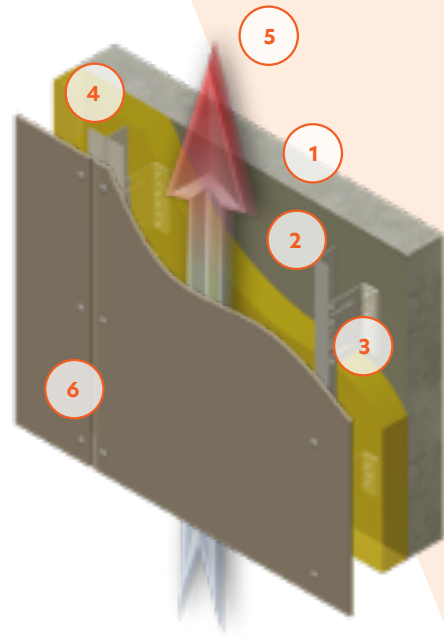

Types

Closed jointed - Back ventilated and drained system

Ventilation is achieved by openings at top and base of cladding. Moisture build up at rear of panels will be either drained at the base or thermally evaporated.

Open jointed - Pressure equalised system

When the outside air pressure is transferred to the air cavity behind the cladding panel, the cladding is exposed to a near-zero pressure differential thus avoiding wind driven rain getting into the cavity through the open joints. A compartmented air cavity is required.

Benefits of Rainscreen Cladding Systems



Façade Design

- Rejuvenation of the façade
- New build and refurbishment projects
- Low or high-rise applications
- Use different colours & textures
- Design flexibility
- Make a statement or blend with the environment
- Consistent high-quality finish



Technical Advantages

- Main building structure protection
- Lightweight materials
- Reduction of applied loads
- Durable and low maintenance finish
- Thermal & Condensation control
- Reduced installation times
- Fabrication offsite
- Reduction of on-site waste
- Accurate cost estimation

Petrarch Application

Petrarch has been designed and installed as a rainscreen cladding system with open and closed joints in many developments throughout the UK, Europe and the US.

The air gap from face of insulation to rear of the Petrarch panels must be a minimum of:

- 25mm - visible fixed system to aluminium vertical rails.
- 50mm - visible fixed system to timber battens and mechanical secret fixed system
- Or that advised by local or national building regulations

Subframe profiles must always be laid vertically to allow for a continuous vertical airflow and panels installed with a minimum joint width of 10mm.

Structural movement and/or deflection joints must be absorbed by the support framing and cannot be transferred to the cladding panels.



Approvals

Petrarch has been tested in the UK as an open jointed system for both visible and mechanical secret fix systems according to CWCT "Standard for systemised building envelopes" thus complying with NHBC Guidelines set out on chapter 6.9.

Petrarch A2-s1, d0 has been awarded BBA certificate 21/5873. And is compliant with NHBC Guidelines set out on chapter 6.9.



If seeking NHBC approval, Part 6 Chapter 6.9 must be followed:

Air gaps should be adequately ventilated, and the following minimum widths maintained behind all rainscreen panels:

- 50mm for panels with open joints
- 38mm for panels with baffled or labyrinth (rebated) joints
- Open, baffled or labyrinth (rebated) joints should have a minimum 10mm opening, unless specified otherwise.

Rainscreen cladding systems that have open joints between the panels should be designed to be pressure equalised. The cavity should be compartmented by:

- a horizontal cavity closer at each floor level
- vertical cavity closers at centres not exceeding 6m
- vertical cavity closers at centres not exceeding 1.5m within 6m of an internal or external corner
- a vertical cavity closer as close as possible to an external corner, generally within 300mm.

Fire cavity barriers that are provided to control the spread of smoke and fire may also be used to form the compartments.

SECTION 3 PETRARCH RAINSCREEN SYSTEMS

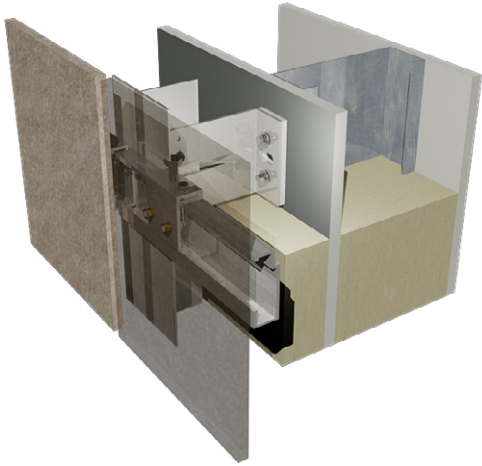

Mechanical Secret Fix

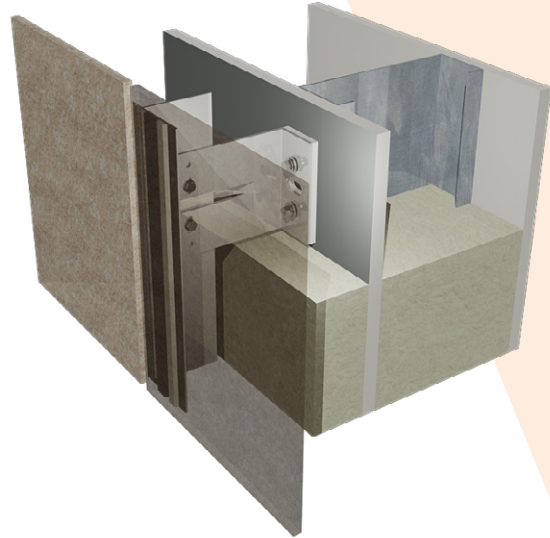

Adhesive Fix

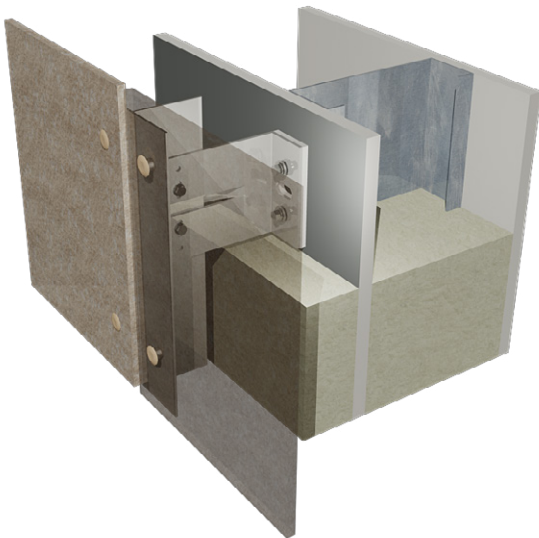

Visible Fixing
(Rivets to Aluminium Subframe)

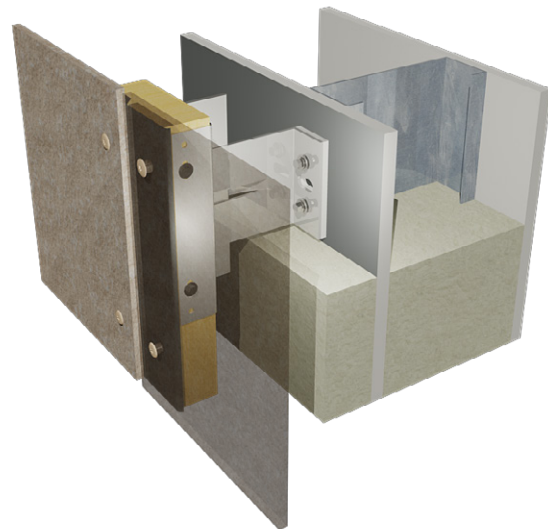

Visible Fixing
(Screws to Timber battens)

Please note, all illustrations in the brochure are representations of the system and structural design analysis must be sought on a project basis. Technical guide to be read in conjunction with typical CAD details and Downer framing technical guide relevant to the system.

MECHANICAL SECRET FIX APPLICATION



3.1 Mechanical Secret Fix Application (Downer DCS004 Support System)

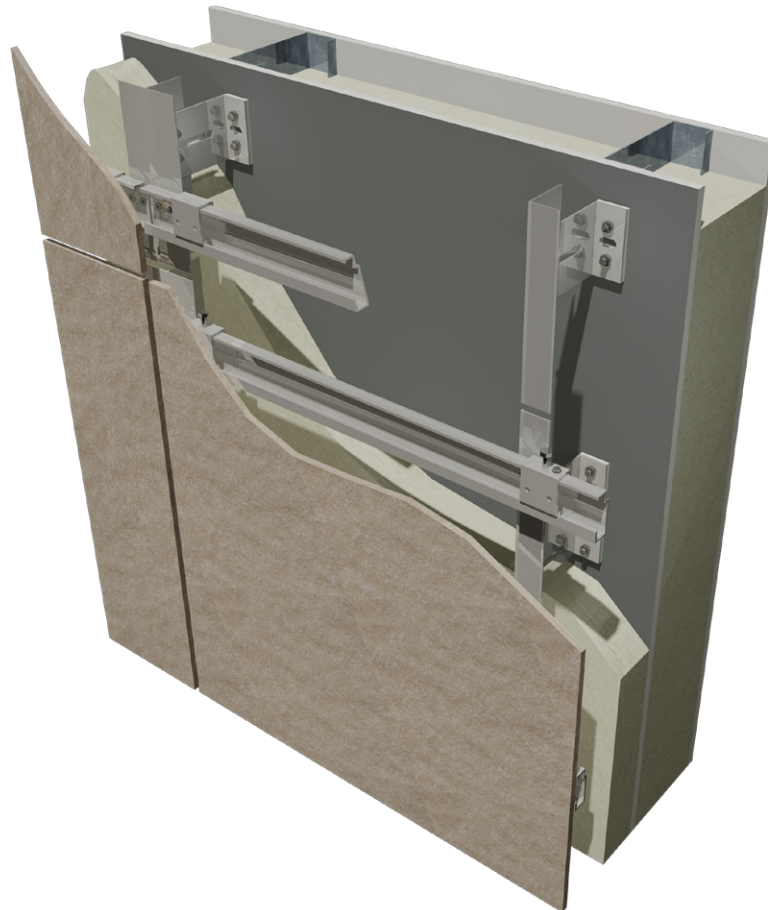

Overview

The Petrarch panels are attached to the prebuilt rainscreen sub grid using a combination of the array of panel hangers and the horizontal cladding rail.

This system relies upon the use of aluminium Panel Hangers fixed to the rear face of the nominal 10mm Petrarch panels. A 7.5mm deep Fischer threaded insert is located into factory prepared blind holes drilled into the back of each of the panels. Each Panel Hanger is individually secured using two inserts and two machine screws. The machine screws are generally factory fitted and torque loaded after installation.

The load carrying capacity of the expanding board anchors depends upon the precision of fabrication, therefore Panel Hanger preparation is carried out in the fabrication unit.

For installation of DCS031 Helping Hand, DCS021 Omega and Zed or DCS041 Floor to Floor Framing System please refer to relevant technical guide.

Components

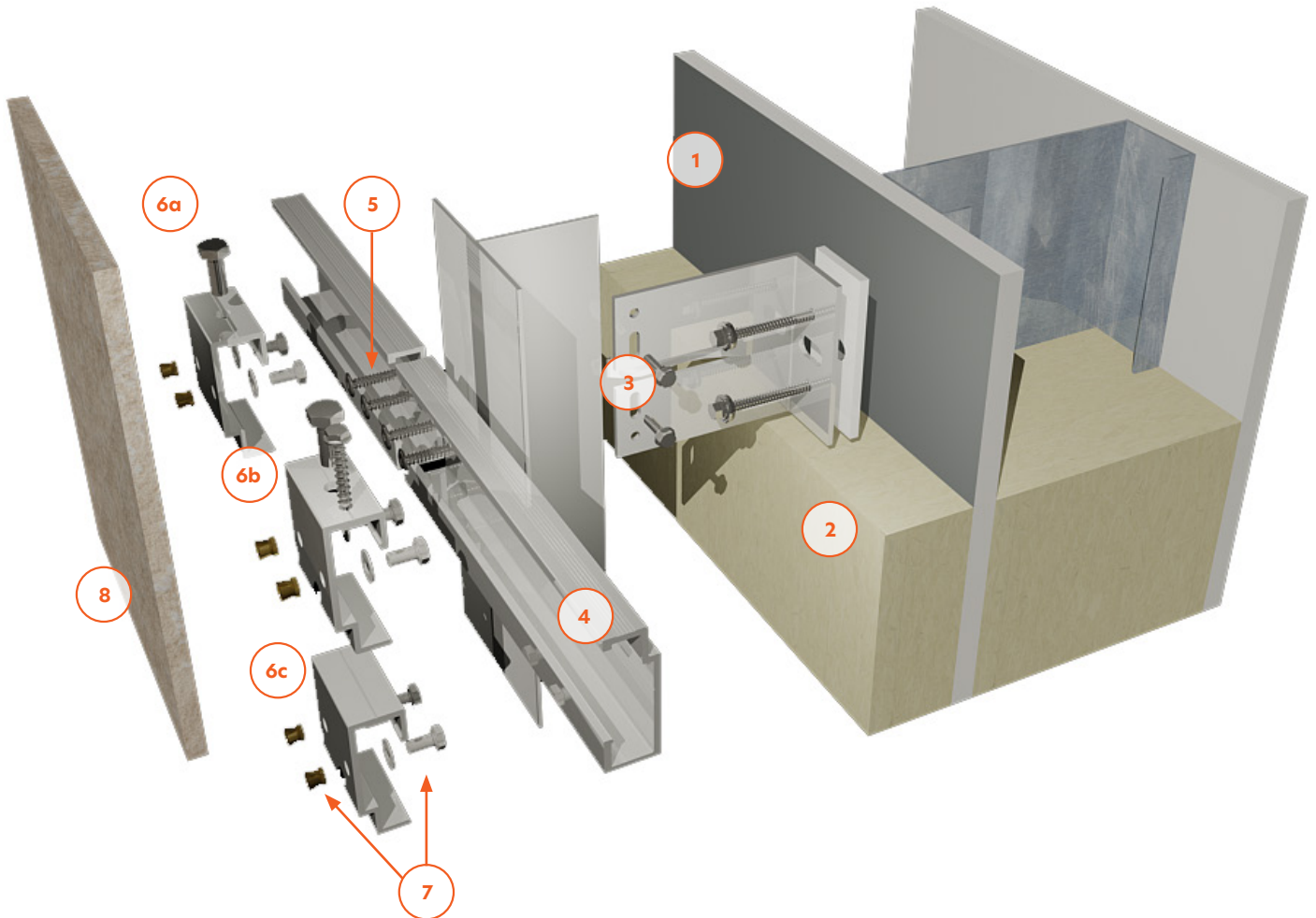

Build-Up

1. Substructure
2. Insulation (refer to section 4.7)
3. DCS031 Helping Hand System (Isolator Pad, Helping Hand Bracket, vertical rail and screws)
4. DCS004 Horizontal Carrier Rail (HCR)
5. Low Profile 5.5x25mm screws
6. DCS004 Panel Hanger
 - a. Adjustable Panel Hanger (top row)
 - b. Adjustable/Fix Panel Hanger (1no. top row)
 - c. Standard Panel Hanger (all others)
7. PA4 Insert, washer and bolt
8. 10mm Petrarch Panel

DCS004 Panel hangers setting out

The location and spacing of each of the Panel Hangers is determined by the overall size of the Petrarch panel, its orientation on the façade and in accordance with the structural engineer's calculations or necessary building regulation.

Please refer to table below for unfactored wind load values and DCS004 hangers spacing:

Un-factored Wind Load (kN/m ²)						
Y Axis (Vertical)	X Axis (Horizontal Direction)					
	mm	400	450	500	550	600
	400	4.74*	4.21*	3.79*	3.44*	3.16*
	450		3.74*	3.37*	3.06*	2.81*
	500			3.03*	2.75*	2.52*
	550				2.50*	2.29
	600					2.10

* Wind Load based only on fixing tested resistance in accordance with EAD 090062-00-0404 : 2018. Petrarch panels tested to 2.4kN/m² serviceability and 3.6kN/m² safety according to CWCT guidelines.

- Adjustable / Fix Panel Hanger
- Adjustable Panel Hanger
- Standard Panel Hanger

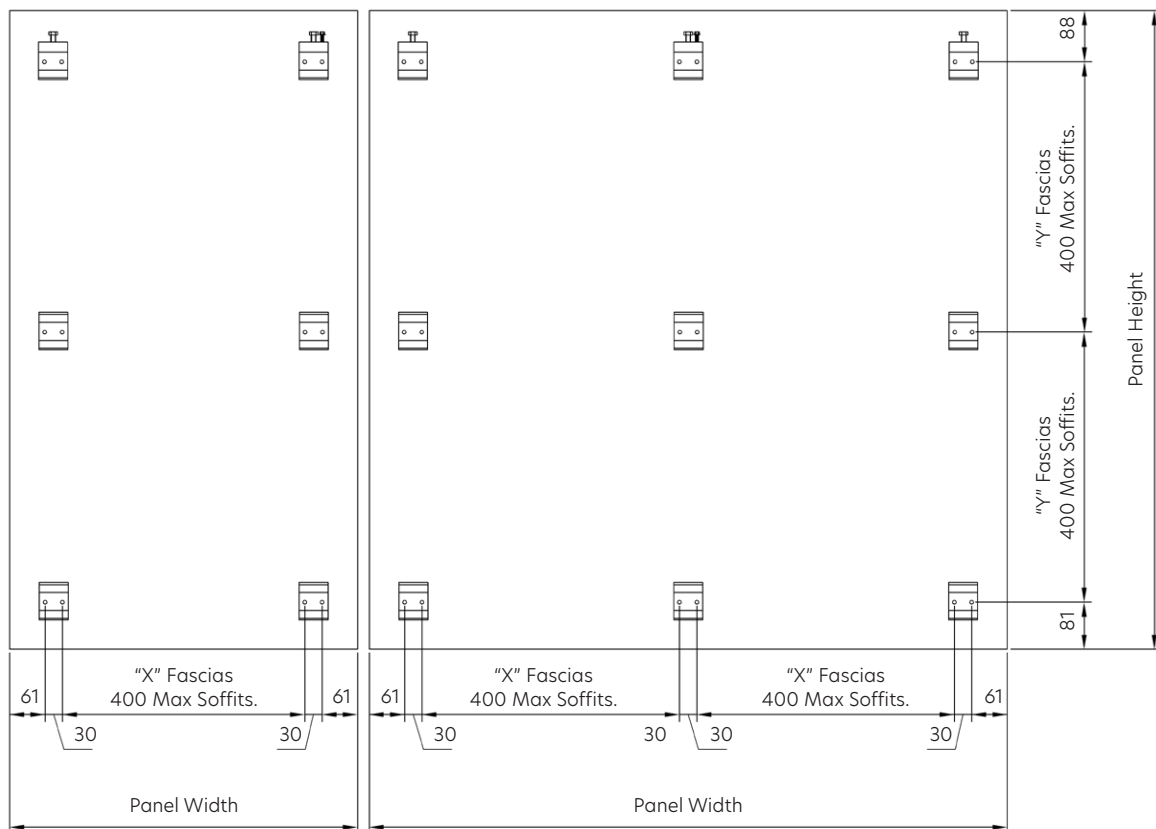

Standard panel should have a minimum of 2no. panel hangers on width and 2no. panel hangers on height. Minimum standard panel size 300mm (W) x 300mm (H).

On panels with special fabrication such as cut-outs or apertures, maximum edge distance to fixing 150mm.

Fabrication detailing and requirements

Panel schedule denoting panel references, width, height and quantity in excel or PDF format along with individual fabrication drawings per panel in DWG or PDF format depicting panel hanger set-out and any additional fabrication such as routs, corners, etc. will be required so that the data can be programmed into our CNC machine.

Please note, as a guideline we require between 3-5 days from receipt of final details per schedule for due diligence cross checking and issuing of final instruction to works.

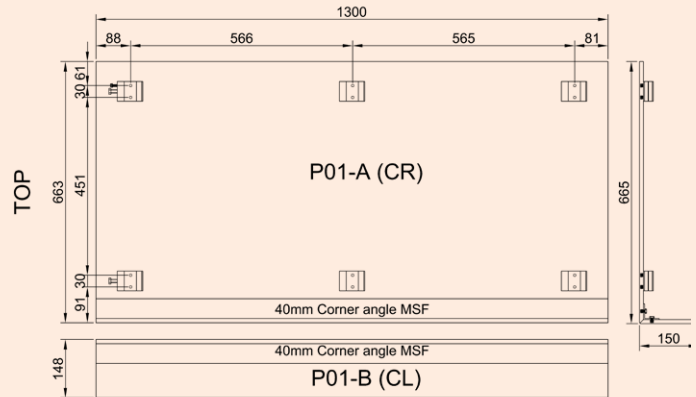

Sub grid recommended setting out

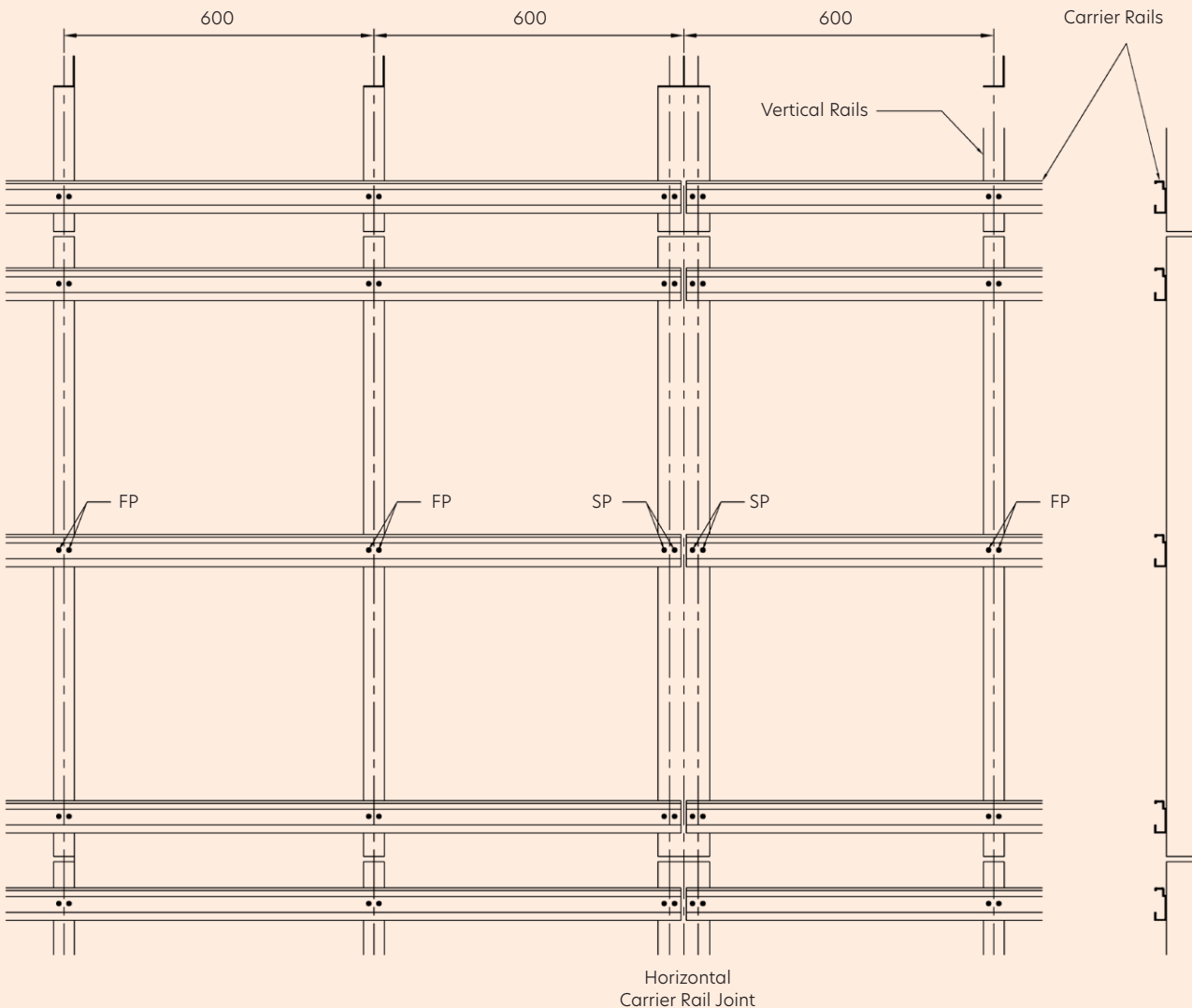

NOTE: The fixing procedure for the DCS004 horizontal carrier rail in max. 3m lengths is as follows:

- Fixing HCR to L rail - all double fixed point (FP)
- Fixing HCR ends to T rail - all double sliding point (SP) - HCR only drill holes 10mm

Petrarch Panel Installation

Once the Horizontal Cladding Rails have been installed and fully fixed into the sub grid the panels can be installed onto the the rails.

DCS004 Mechanical Secret Fix is a hook-on system with fine level adjustment required to top row of panel hangers and as such is required to be installed in sequence standard left to right from ground floor upwards.

Each Petrarch panel can now be lifted into place and each Panel Hanger hooked onto the corresponding Horizontal Cladding Rail.

Position the panel in its final location and using a suitable ratchet spanner adjust the M8 x 14mm hexagonal machine screw located in the top of the two outer Adjustable Panel Hangers to level the panel, followed by adjusting all other levelling screws to bear on the Horizontal Carrier Rail

Adjustable panel hangers allow for a $\pm 5\text{mm}$ adjustment.

NB: A lift of 18mm will allow the panel hanger to clear the horizontal rail. Therefore, we advise a minimum of 25mm clearance gap for ease of installation.

By carrying out this adjustment, the pitch and joint width of the rainscreen panel and the adjacent panels can be set. Once this process has been completed then a TEK Screw 5.5 x 35 mm is inserted into the pilot hole in the top of the Adjustable/Fixed Panel Hanger. This will lock the panels onto the Horizontal Cladding Rail, and will prevent any lateral movement along the rails.

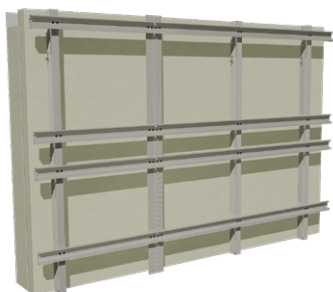

Step 1
HCR Installation

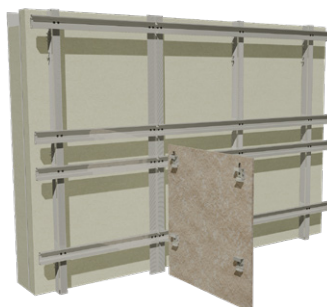

Step 2
MSF standard installation left to right from ground floor upwards



Step 3
Level, lock panel and continue installation of first row of panels



Step 4
Continue with 2nd row



Installation Completed

ADHESIVE SECRET FIXING APPLICATION



3.2 Adhesive Secret Fixing Application

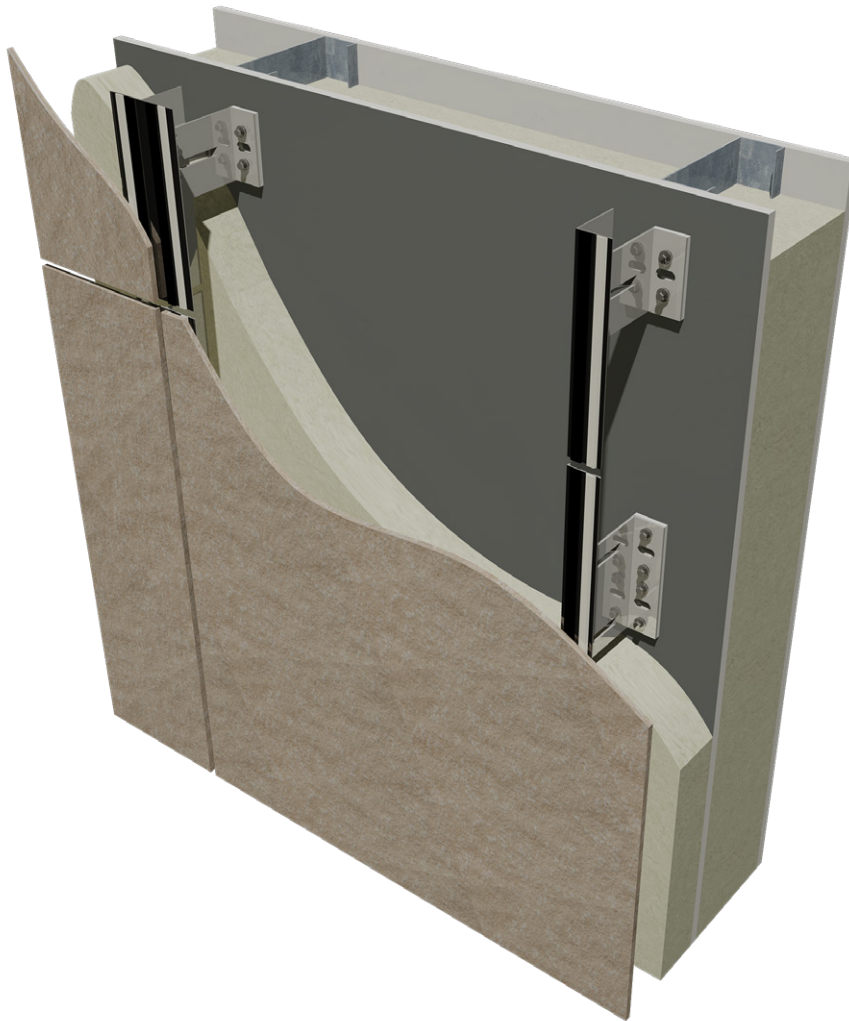

Overview

Petrarch panels can be secretly installed back to a vertical grid of extruded aluminium support frames using an approved adhesive system.

For installation of DCS031 Helping Hand, DCS021 Omega and Zed or DCS041 Floor to Floor Framing System please refer to relevant technical guide.

Components

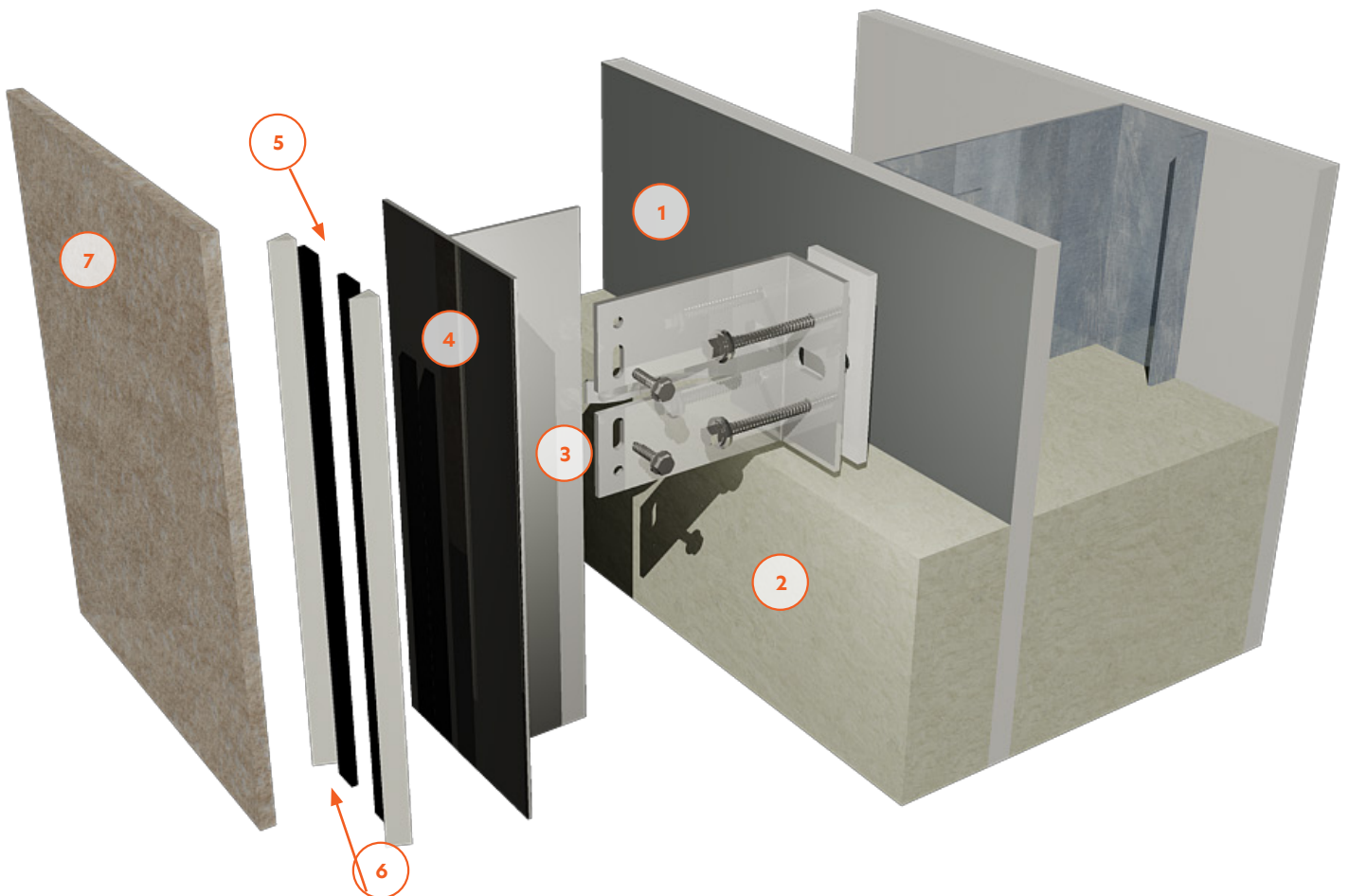

Build-Up

1. Substructure
2. Insulation (refer to section 4.7)
3. DCS031 Helping Hand System (Isolator Pad, Helping Hand Bracket, vertical rail and screws)
4. Face of rail pre-treated with Cleaner and/or Primer
5. Double sided tape
6. Adhesive Beads
7. Petrarch Panel

General Guidelines Adhesive Fixing

Please refer to each adhesive manufacturer's specific guidelines

Aluminium Substructures

1. Clean with a fine abrasive pad, clean the surface and apply Activator / Primer as recommended by adhesive manufacturer. Please check flash off times before moving to the next step.

Cladding Panels

1. Petrarch Smooth/Riven Matt finish are supplied with the rear face already shotblasted. However, all other variants of Petrarch will require abrading following adhesive manufacturers' recommendations.
2. Surface to be bonded must be clean, dry and free from grease before applying Activator / Primer as recommended by adhesive manufacturer. Please check flash off times before moving to the next step.

Adhesive Application

1. Apply Double Sided Fixing Tape over the whole length of the vertical rails and parallel to the edges. Do not pull off the protective foil at this time.
2. Apply adhesive following manufacturers guidelines. Please check waiting times to install the panels.

Panel Installation

1. Remove the protective foil on the Double Sided Tape.
2. Place Petrarch panels in the required position on the adhesive bead without the panel touching the fixing tape.
3. Position the panels precisely and press them firmly until they contact the Double Sided Tape.

Approved Tested Adhesive Systems

Country	Adhesive Supplier
UK	Sika
US	Sika US
Europe	Innotec
	Bostik

Panels should be fixed in accordance with the structural engineer calculations or applicable building regulations.

All project specific calculations such as feasibility and maximum panel widths for project specific landscape panels should be sought directly from adhesive manufacturer.

3.3 Visible Fixing Application

Petrarch panels can be installed back to a vertical metal support frame such as our Downer DCS031, DCS041 and DCS021 Subframe Systems or back to a timber batten subgrid.

Both 7mm and 10mm Petrarch can be installed using a visible rivet (metal subframe) or torx screw (to timber battens).

If required, Petrarch panels can be supplied pre drilled to site. A drill pattern layout drawing will be required for each panel type, so that the data can be programmed into our CNC drilling machine

Colour coated rivets or screws are supplied to match where possible the surface finish of the Petrarch board. It is usual to obtain approval of the rivet colour during the design development process.

Where Petrarch is to be supplied in the riven surface texture the rivets/screws are supplied with a gasket washer located under the fixing head, to even out seating of the rivet onto the localised area.

RIVETS TO METAL SUBFRAME



3.3.1 Rivets to metal subframe

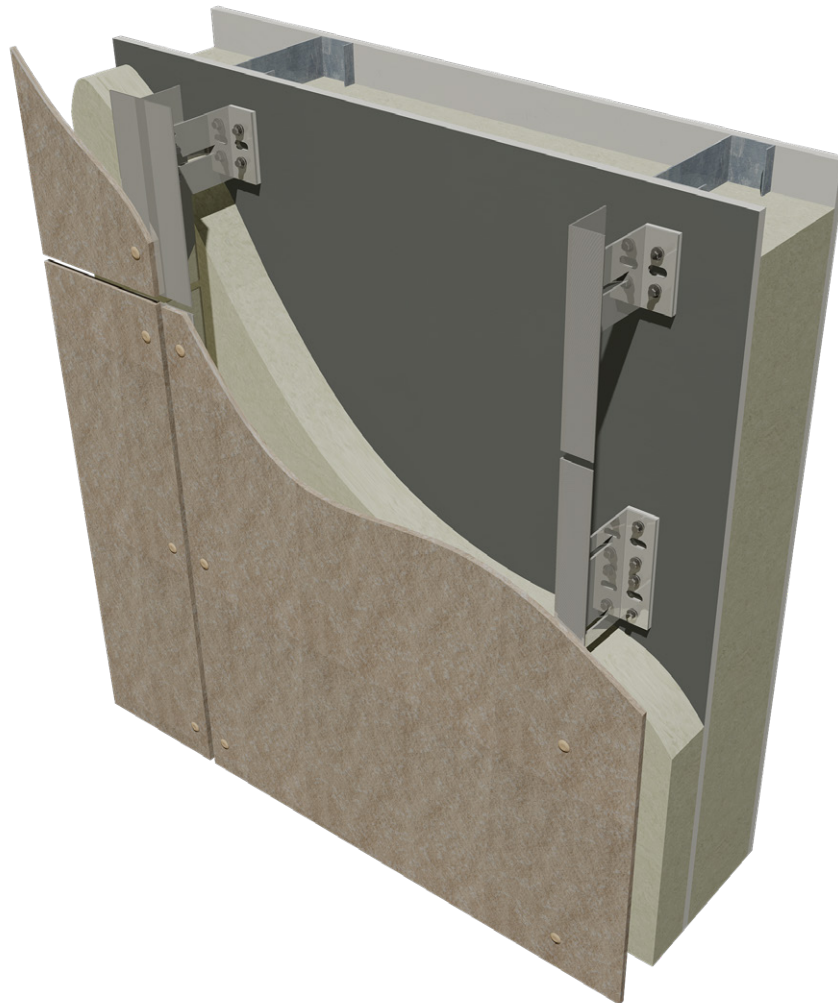

For installation of DCS031 Helping Hand, DCS021 Omega and Zed or DCS041 Floor to Floor Framing System please refer to relevant technical guide.

Components

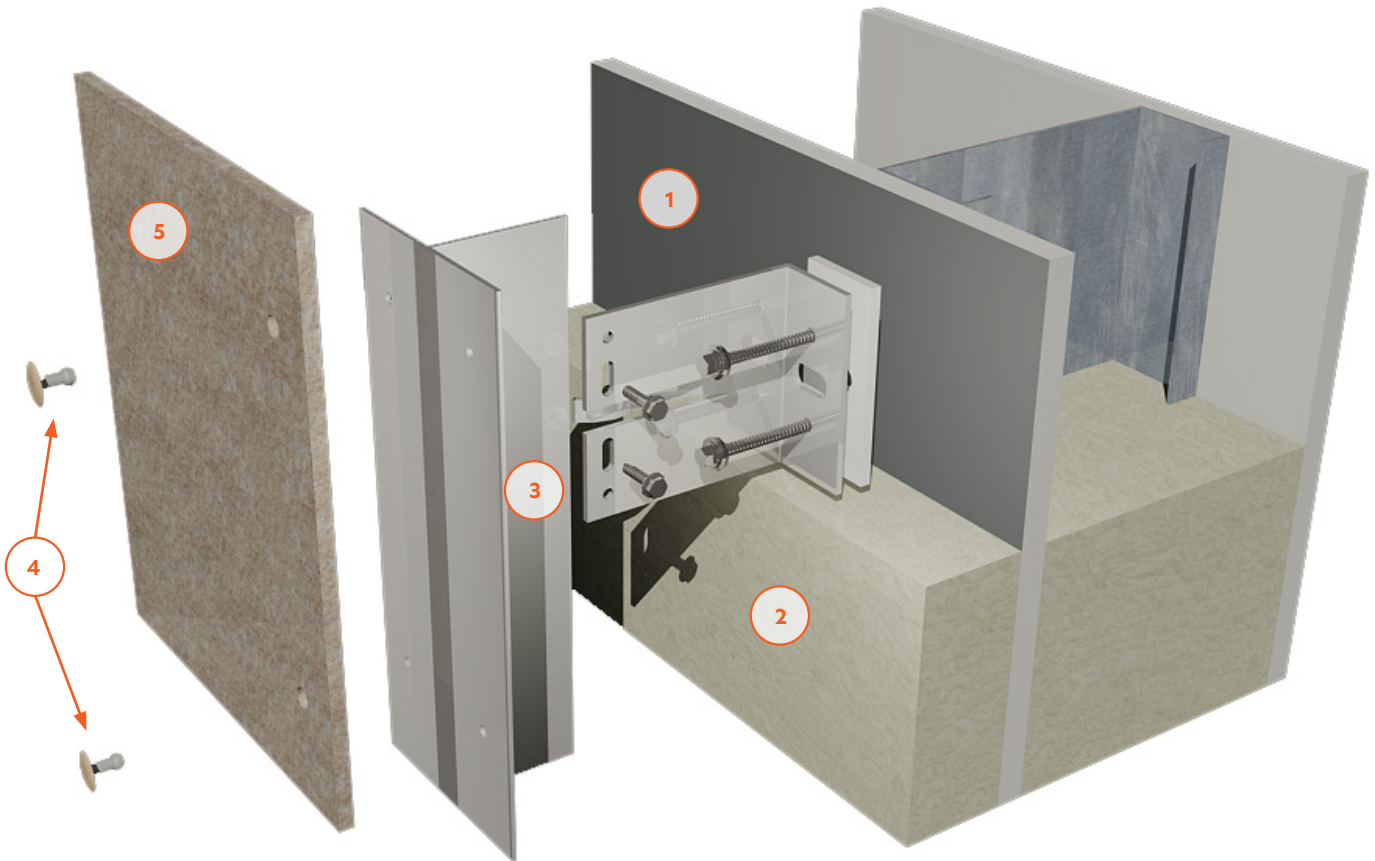

Build-Up

1. Substructure
2. Insulation (refer to section 4.7)
3. DCS031 Helping Hand System (Isolator Pad, Helping Hand Bracket, vertical rail and screws)
4. Colour match Rivets
 - a. 7mm Petrarch - 4.8x18mm 16mm Head
 - b. 10mm Petrarch - 4.8x25mm 16mm Head

Panel Fixing Set out - Sliding and Fixed Points

Panel fixings should be set out in accordance with the structural engineer's calculations or necessary building regulations. Please refer to table below for unfactored wind load values and panel fixing spacing:

Un-factored Wind Load (kN/m ²)								
Y Axis (Vertical)	X Axis (Horizontal Direction)							
	mm	300	350	400	450	500	550	600
300		4.49*	3.85*	3.37*	2.99*	2.69*	2.45*	2.24
350			3.30*	2.89*	2.57*	2.31	2.10	1.92
400				2.53*	2.24	2.02	1.84	1.68
450					1.99	1.79	1.63	1.49
500						1.61	1.47	1.34
550							1.33	1.22
600								1.12

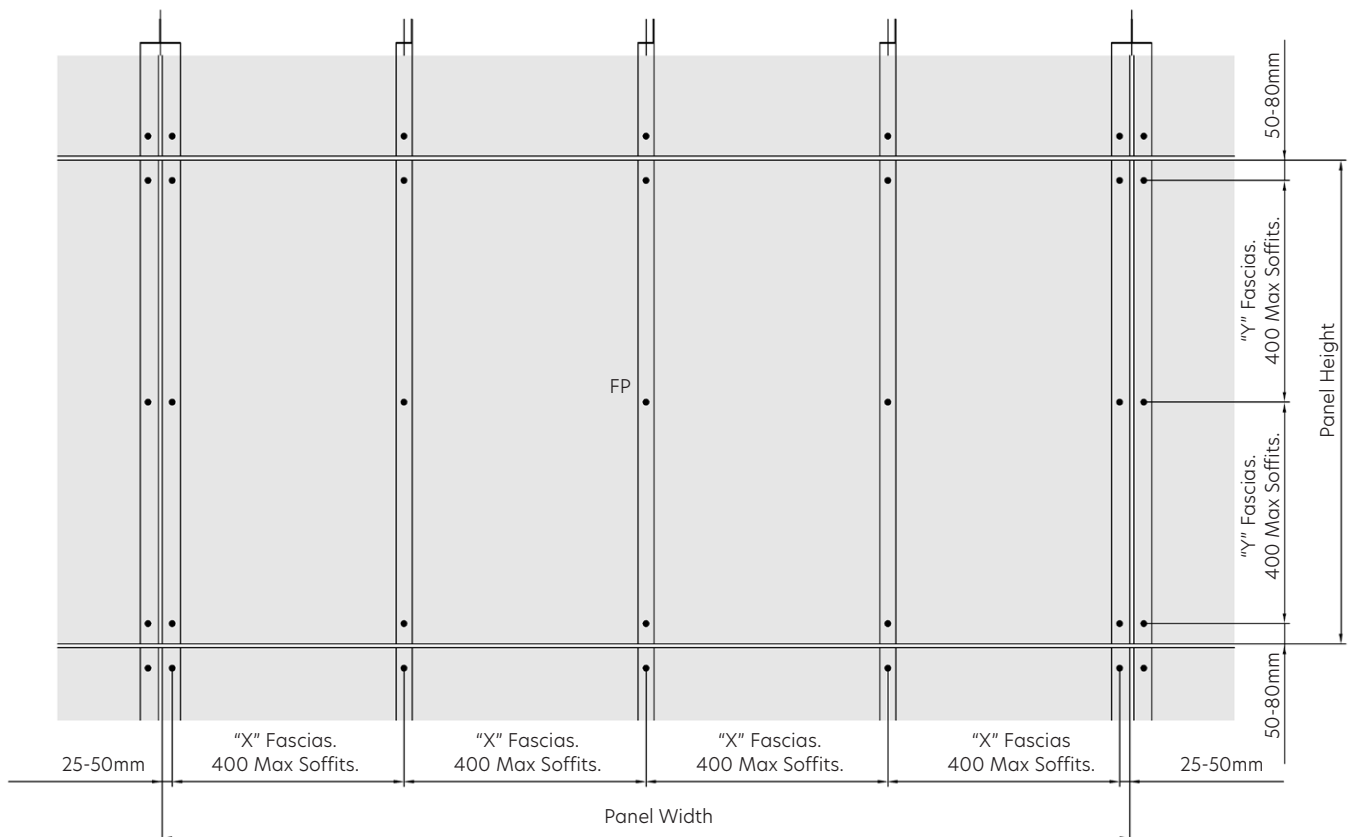

On panels with special fabrication such as cut-outs or apertures, maximum edge distance to fixing 100mm.

Method Statement (Rivets).

1) The drill holes in the Petrarch panels should be one Ø4.9mm hole as the fixed point positioned close to the panel centre, the remaining drill holes are Ø9.5mm and are sliding points. Drill hole locations are positioned working from the panel centre, outwards.

2) The edge distance for drill holes in all Petrarch panels, (both 7mm and 10mm) is a minimum of 25mm from the vertical edge of the panel and 50-80mm from the horizontal panel edge.

3) The corresponding drill holes in the supporting sub frame should always be Ø4.9mm and positioned centrally within the panel drill holes. A centralising tool is required to ensure that this is adhered to. Once the Petrarch panel has been positioned on the sub grid and clamped into place, drill each of these holes starting at the fixed point and working outwards with the sliding points.



Centralising Tool

4) Rivets for 7mm Petrarch should be large flange Aluminium/Stainless 4.8mm x 18mm (grip range 6.5:12.5mm) with Ø16mm head powder coated to a specific panel colour. Use on the Riven surface also

requires the fitting of a Black Rubber Gasket Washer 4.3x1x14 located under the rivet head.

5) Rivets for 10mm Petrarch should be large flange Aluminium/Stainless 4.8mm x 23mm (grip range 11.0-19.5mm) with Ø16mm head powder coated to a specific panel colour. Riven surface also requires the fitting of Black Rubber Gasket Washer 4.3x1x14 located under the rivet head.

6) All Rivets should be installed using a Soft Set Nosepiece or "stand-off head" type G3 Thread M10 x 1 16mm head always allowing for a 0.3mm clearance between the underside of the rivet head and the face of the Petrarch panel. To accommodate the expansion and contraction of the Petrarch panel all rivets need to be installed with this method.



Nose Piece

7) The minimum panel joint for Petrarch is 10mm for both horizontal and vertical joints between panels.

Panel fixings should always be installed starting from the centre of the panel moving outwards using a Centralising Tool and Nose Piece.

Stainless steel / stainless steel rivets must be used for steel subframes.

Coastal and industrial areas require the use of wholly stainless steel A4 grade rivets.

SCREWS TO TIMBER BATTENS

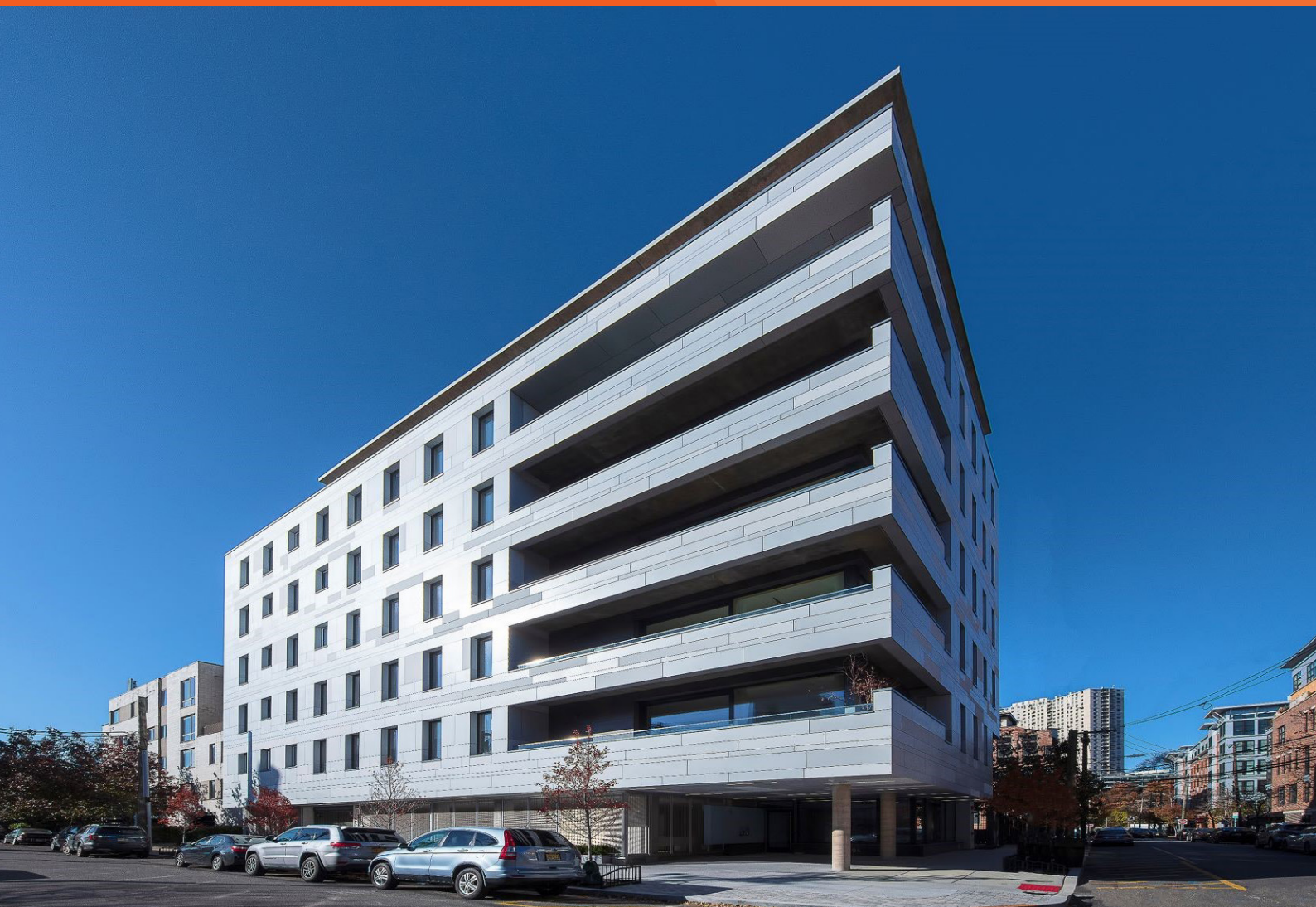

3.3.2 Screws to timber battens

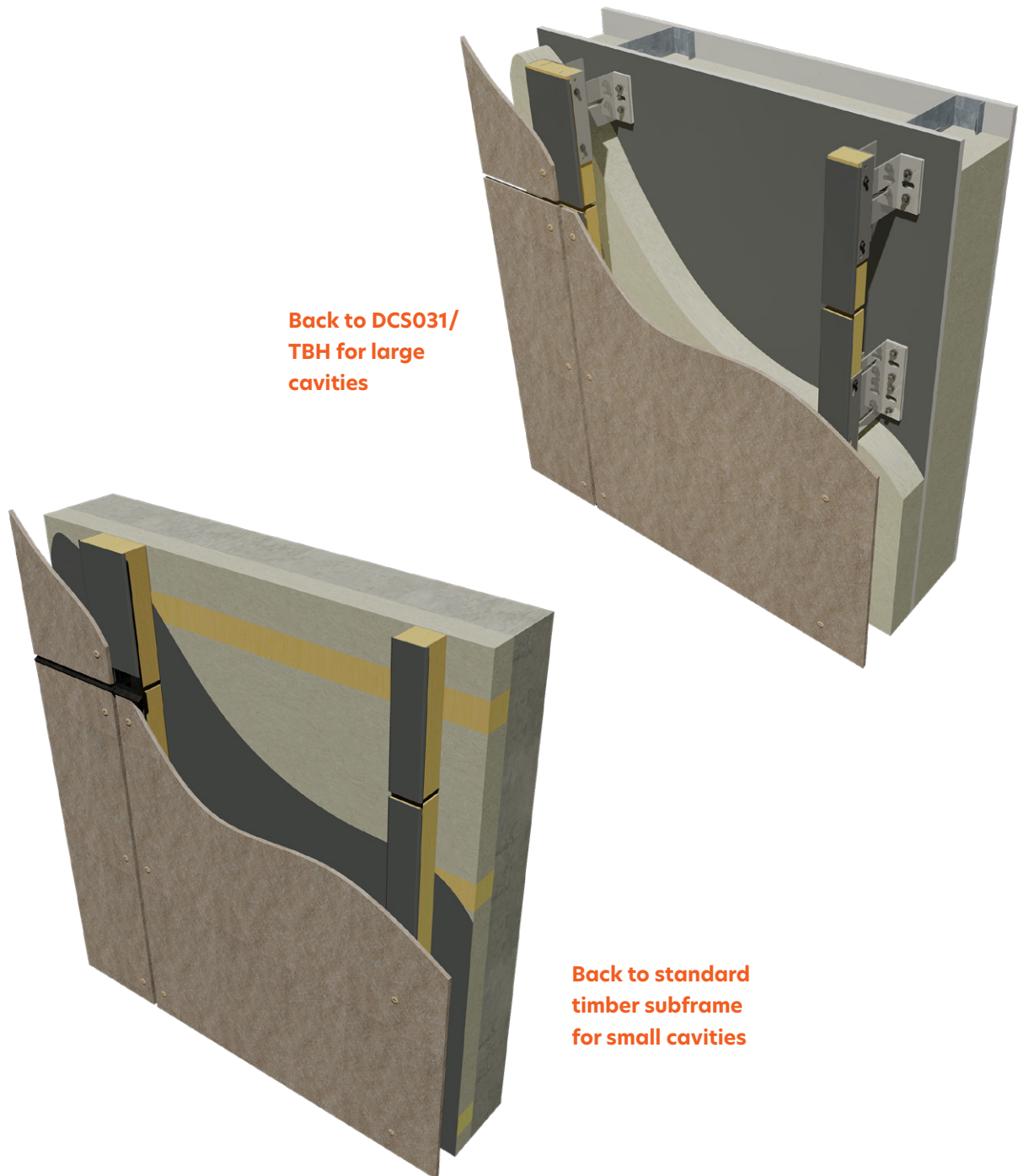

For installation of DCS031 Helping Hand with Timber Batten Holders please refer to relevant technical guide.

Petrarch do not supply timber battens and any liability for the timber substructure is excluded. Instructions given by the substructure manufacturer must be followed.

Components

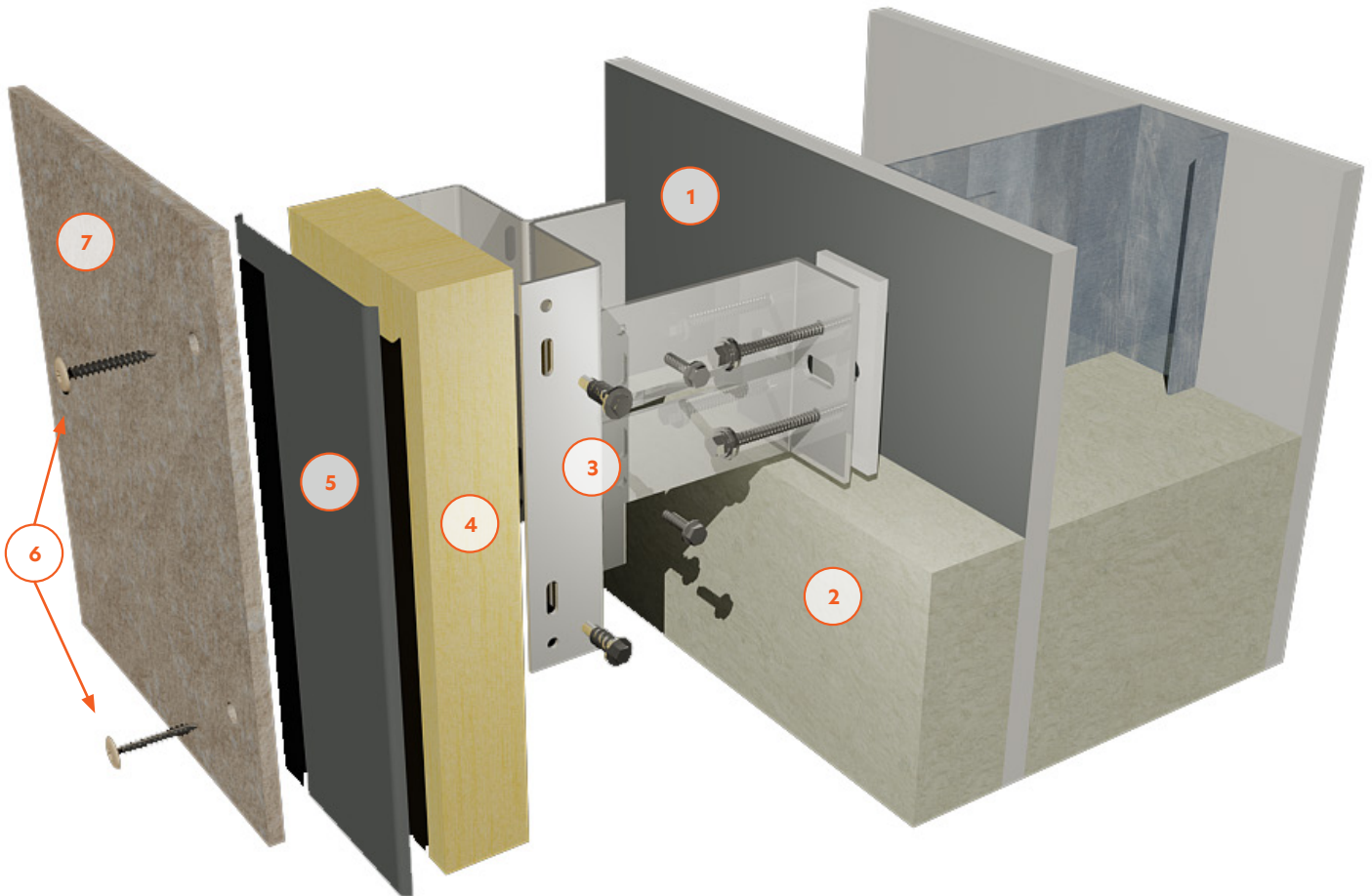

Build-Up

1. Substructure
2. Insulation (refer to section 4.7)
3. DCS031 Helping Hand System (Isolator Pad, Helping Hand Bracket, Timber Batten Holder and screws)
4. Timber Batten
5. EPDM Strip
6. Colour match 4.8x35mm 14mm Head Torx Screws
7. Petrarch Panel

Drill Hole Locations - Sliding and Fixed Points.

Panel fixings spacing is determined by the overall size of the Petrarch panel, its orientation on the façade and in accordance with the structural engineers' calculations or necessary building regulation.

However, these should not exceed 600mm centres for fascias or 400mm centres for soffits both vertically & horizontally.

Fix / Sliding Points Set out

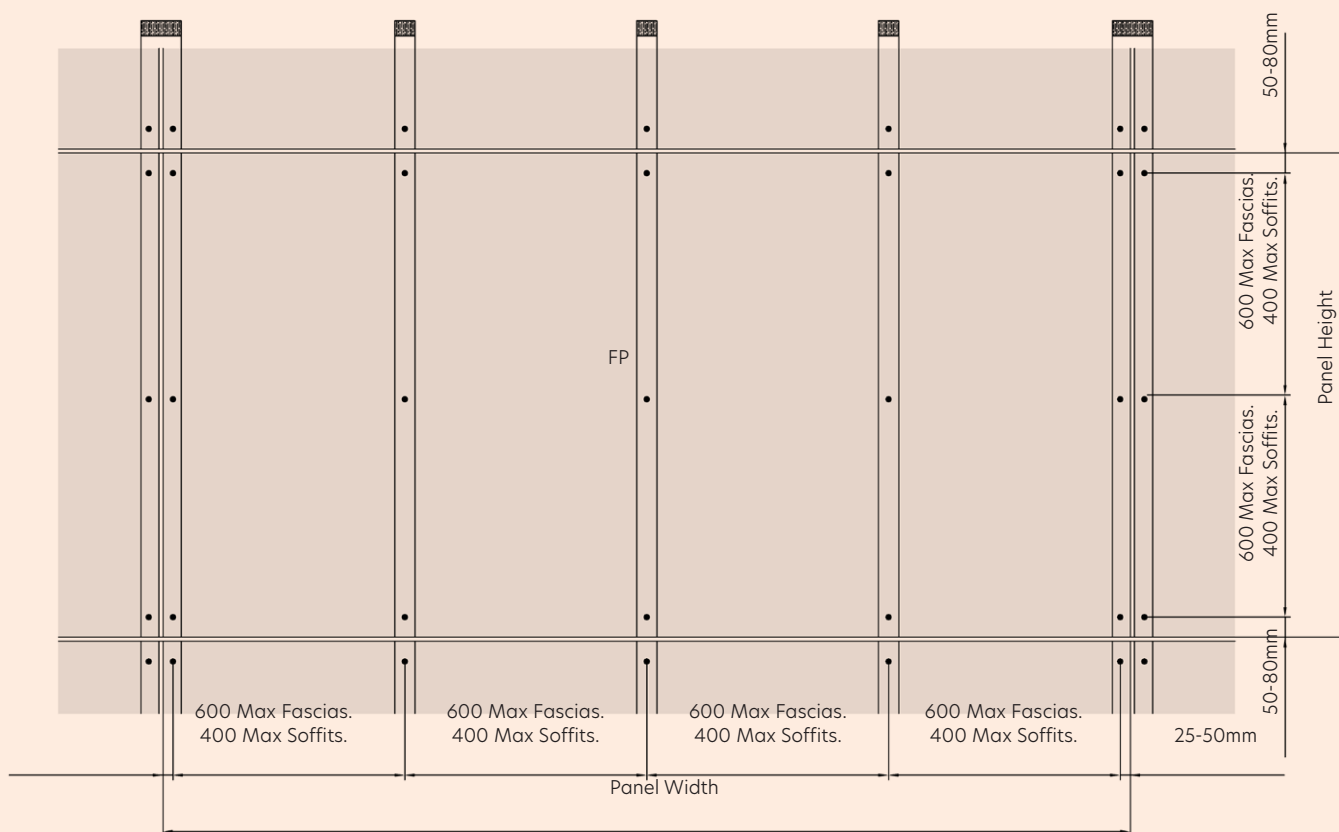

Method Statement (Screws).

1) The drill holes in the Petrarch panels should be one Ø4.9mm hole as the fixed point positioned close to the panel centre, the remaining drill holes are Ø9.5mm and are sliding points. Drill hole locations are positioned working from the panel centre, outwards.

2) Vertical battens at panel joints should be a minimum of 100x38mm and intermediate battens should be a minimum of 50x38mm.

3) Battens receiving the panel should be covered with EPDM at panel joints and intermediate battens with an overhang of minimum 5mm.

4) The edge distance for drill holes in all Petrarch panels, (both 7mm and 10mm) is a minimum of 25mm from the vertical edge of the panel and 50-80mm from the horizontal panel edge.

5) Torx Screws for both 7 & 10mm Petrarch should be 4.8x38mm 14mm Head Low profile A2 Stainless Steel powder coated to a specific panel colour. Use on the Riven surface also requires the fitting of a Black Rubber Gasket Washer 4.5x1x8 located under the screw head.



Coastal and industrial areas require the use of stainless steel A4 grade screws.

6) The minimum panel joint for Petrarch is 10mm for both horizontal and vertical joints between panels.

7) Horizontal joints should be protected by using a joint profile that directs the water away from the joint such as chair or L shaped profiles. Birds Beak and flat profiles are not suitable for this application.

Panel fixings should always be installed starting from the centre of the panel moving outwards.

Torx screws should not be screwed further than the surface of the panel and must not be over tightened.

SECTION 4

DETAILING/ACCESSORIES/ DESIGN CONSIDERATIONS

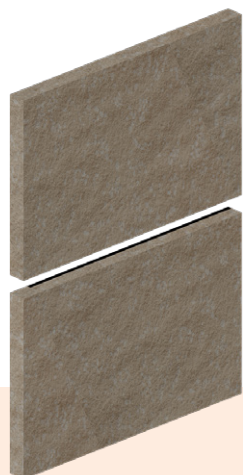

4.1 Panel Joints

Open Joint

Simple and effective open joint enables an accurate and clean panel connection with no additional fabrication. Joint width 10mm.

Martlet Joint

Factory fabricated overlapping concealed joints for an elegant and monolithic design. Joint width 10mm.

Note: Martlet joints are only available on 10mm Petrarch panels either vertically or horizontally, on each panel, NOT both.

The minimum width and depth of the Martlet Joint is 10mm wide x 5mm in depth.

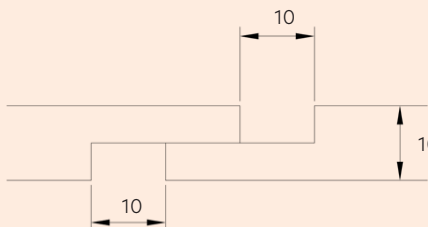
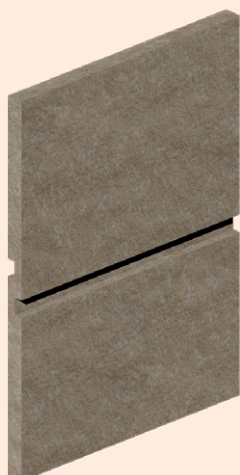

IMPORTANT: when designing with martlet joints, 20mm will need to be added to panel width (vertical joints) or panel height (horizontal joints) when material is removed from face of panel to fabricate the martlet.

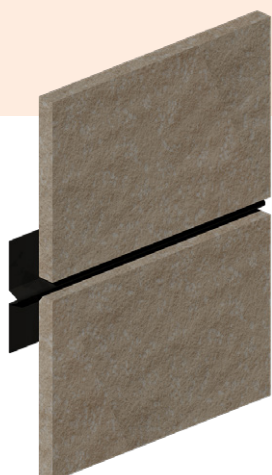
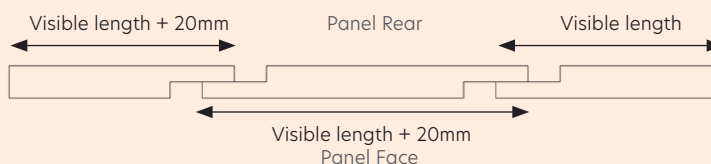

Baffled Joint

Joints closed with flat or birds beak joint profiles, available in any colour *, maybe to match the Petrarch panels or make a statement and emphasise the joint.

* Birds beak is supplied in black as standard. Birds beak or flat profile PPC to match Petrarch are special order items and might be subject to a minimum order quantity.

4.2 Corner Options

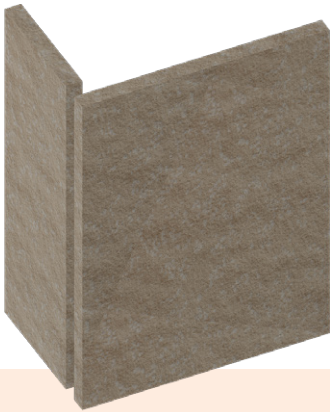

Open Corner

Simple and effective corners enable an accurate and clean finish with minimal additional fabrication.

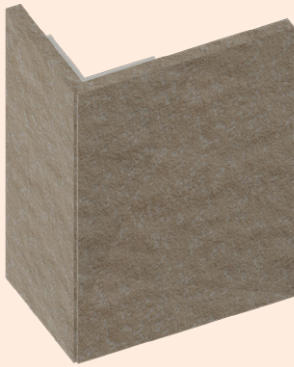
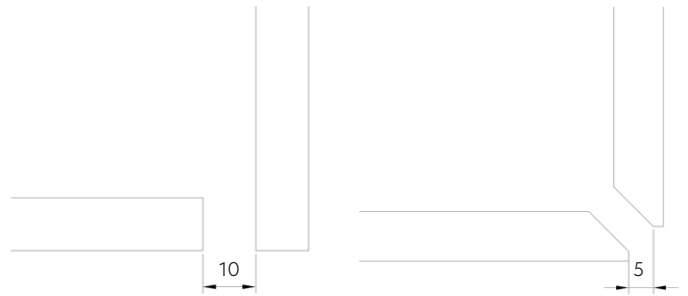

Prefabricated Corner

Factory fabricated corners provide a sleek and elegant design.

Petrarch can be factory fabricated to produce a selection of preformed corner assemblies, all of which are supplied to site ready to install.

Minimum 61mm, maximum 250mm return factory assembled.

Max 150mm unsupported, >150mm extra support is required

Note that prefabricated corners require both adjoining panels to correspond exactly in size to marry up.

Squared*

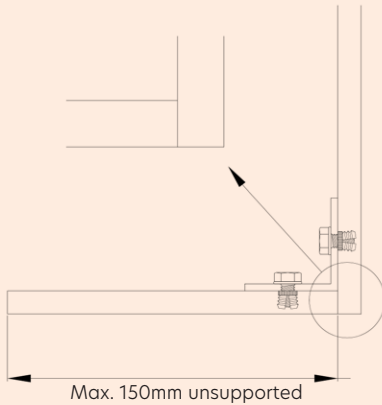

Chamfered*

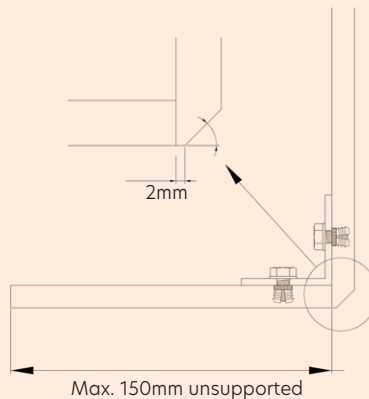

2mm Birds Beak Mitre

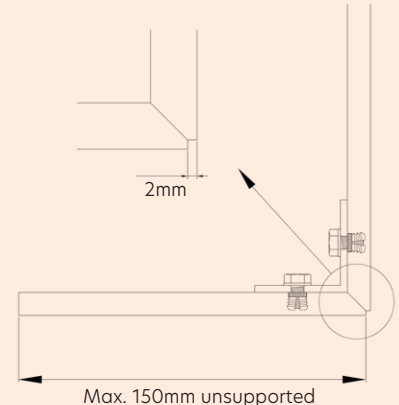

Closed Corner

Corners closed with box profiles, available in any colour*, maybe to match the Petrarch panels, for a simple dressed corner. Minimum 5mm from edge of panel to profile.

* PVC Black or mill finish Aluminium external corner profiles are supplied as standard. PPC to match Petrarch are special order items and might be subject to a minimum order quantity.

** Due to Petrarch cutting and board thickness tolerance, both squared and chamfered a hairline corner joint might be visible.

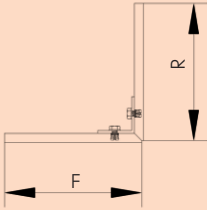
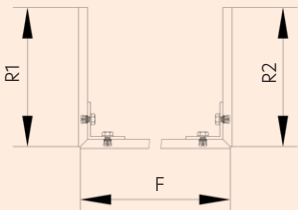
Prefabricated Corner Guidelines			
Shape		Unsupported return/s	Supported return/s >150mm
L-shape*		R ≤ 150mm F ≤ 3040mm	R ≤ 1200mm F ≤ 1200mm
U-shape*		R1 ≤ 150mm R2 ≤ 150mm F ≤ 3040mm	One return unsupported
			Both returns supported
			R1 ≤ 1200mm R2 ≤ 1200mm F ≤ 1200mm R1+F+R2 ≤ 2400mm

*Standard 90° Angle. Please contact Petrarch for project specific requirements.

4.3 Signage; Lighting Fixments; General Attachments

Petrarch panels are not intended as a load bearing element in the wall construction. Any items that are to be positioned on the surface of the external Petrarch board surface should always be supported directly by their fixings. The loading should be carried by the rainscreen support frame or alternatively by the structural framing members.

Any fixings that penetrate through the Petrarch panels need to be positioned centrally into clearance holes drilled into the panels, this will allow the Petrarch to expand and contract.

A minimum gap of 3mm is recommended all around the fixing and the edge of the panel.

4.4 Ventilation Gaps & Ground Clearance

Ventilation must be provided at the base and the top of the cladding system as well as above and below interruptions such as windows and doors. As a rule, ventilation gaps should be at least half of the ventilation cavity (distance from face of insulation to back of panels).

We suggest the inlet and outlet gaps at the base and head of the cladding should be a minimum of 25mm and be continuous. The openings should be protected by perforated closures or mesh to prevent entry by birds or vermin. Reduction by insect screens should also be compensated (generally reduction of 40%).

Ground clearance for Petrarch located at the base of the rainscreen wall, first row of panels should be installed with a minimum of 50mm clearance from base of panel to ground.

If using a timber frame, then clearance should be increased to a minimum of 150mm.

NB: under no circumstances should Petrarch panels be allowed to be permanently submersed in running or standing water.

4.5 Panel Perforations

Petrarch panels can be perforated to provide a design feature for incorporation into a façade system.

Please note, the greater the perforated area, the lesser the panel stability. We would therefore advise that no more than a maximum of 15% of the surface area of each panel is removed.

However, as a perforated panel is more fragile, the technical feasibility of the design should be checked & the location of the panel support profiles and fasteners considered. To provide a stable and secure fixing these may have to be increased as required.

As a rule, for Petrarch the remaining material between the perforated areas should be at least the same size as the perforation itself. Panels should always have a non-perforated frame to accommodate the panel fixings.

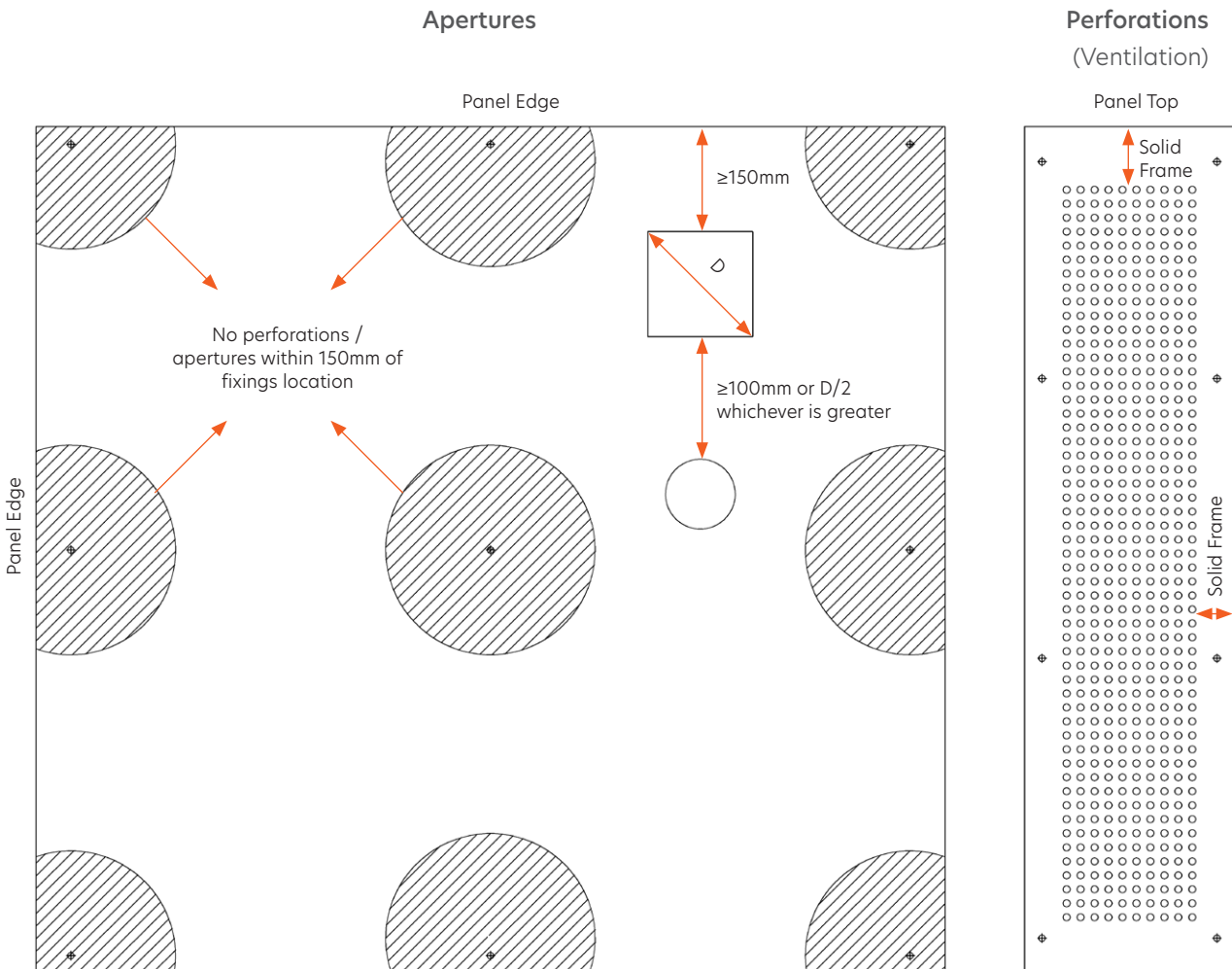

Guideline drawing is provided as general non-project specific recommendation.

Please contact Petrarch for project specific advice.

Please check fixing locations of any other specific fabrication that might interfere with apertures and/or perforations prior to start cutting / drilling.

4.6 Cavity Fire Barriers

Petrarch are aware that as part of a rainscreen system, both vertical and horizontal cavity fire barriers may be required. There are many manufacturers supplying such materials to the UK marketplace.

Therefore, we would refer the design team for a project to the relevant statutory authorities and fire safety technical advisors to ascertain the type and location of cavity fire barriers that may be required for a project.

Petrarch can provide all current fire performance data and certification for Petrarch panels to assist with the overall design and assessment of these requirements.

4.7 Cavity Insulation

Insulation is usually added to the construction of a rainscreen system, Petrarch would always recommend that all insulation that is installed into a rainscreen cavity zone and behind the Petrarch panels is manufactured from mineral wool and the product is designed and tested for use as a component in a rainscreen system.

We would also recommend that the design team always seek advice from the relevant statutory authorities, fire safety technical advisors, and insulation manufacturers to ascertain the type of insulation that is most suitable for the project.

SECTION 5

PETRARCH GENERAL INFORMATION.

5.1 Delivery and Packaging

Generally, Petrarch panels will be delivered to site cut, drilled and incorporating any fabricated features according to the requirements and design of the cladding system.

Most deliveries are made by standard curtain sided lorry with forklift required on site to off-load. Alternative specialist delivery is available under request.



Standard Curtain Sider Loaded with pallets
(flat panels) - stackable



Crates
(panels with panel hangers) - non-stackable

All products leaving our works are packed in a manner to ensure safe delivery to site.

This entails protection by shrink-wrapping and strapping, and with delivery on suitably sized pallets (flat panels) or crates (MSF).

These normally contain a maximum of 1200kgs for safe handling on site.

All panels are labelled on the rear face with a permanent black pen stating panel reference, fabrication (if any), panel size and top of panel.

It should be noted that it is the customer's responsibility to ensure safe unloading of delivery vehicles and that appropriate lifting equipment is available to unload and move the pallets.



Packing process MSF panels
(Crate)

Pallets are made suitable for forklift off-load only as standard. If pallets are required for craning off-load, maximum loading and size must be advised prior to manufacturing of the panels.

5.2 Site Handling

Petrarch panels must be handled with care in order not to damage the edges and surfaces of the high-quality material. Despite the excellent surface hardness, the stack weight of Petrarch is a possible cause of damage. Therefore, any form of dirt or dust between the panels must be avoided.

Petrarch must be secured against slippage during transport.

When handling Petrarch, panels must be lifted straight up. Do not push or pull them over the edge.

Special care needs to be taken when handling narrow panels.

Petrarch panels must be carried and temporarily stored on the edge to avoid damage.

If mechanical lifting equipment is used, the panels should always be properly protected to avoid scuffing from ropes or chains and a "spreader bar" the width of the pallet should be used.

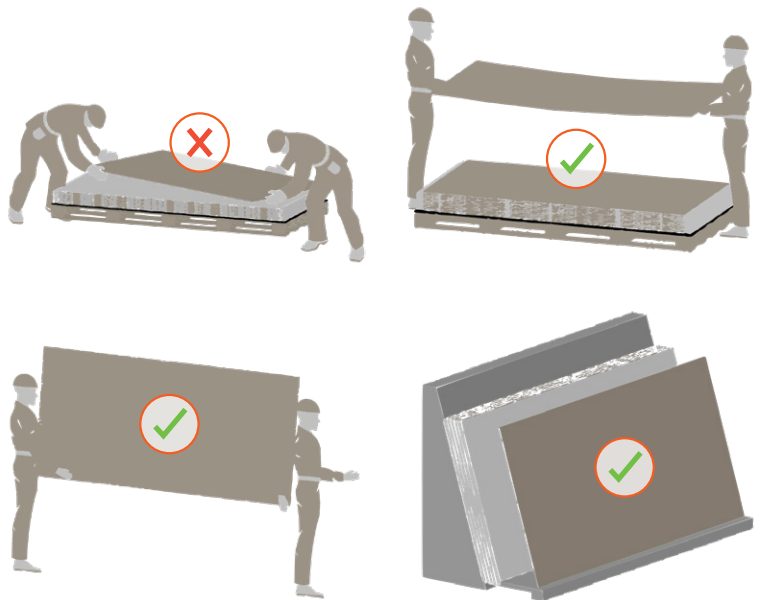

5.3 Storage

A suitable storage area will need to be set aside for the pallets, which should be stored on firm, level surfaces and, to avoid contamination, should be sited away from wet or muddy areas. Material should be protected from the elements and the environment.

Mechanical secret fix crates containing panels with panel hangers on the rear must not be stacked on top of each other. Pallets containing flat panels can be stack up to two pallets high.

Storage should be as near as practical to the areas of working to minimise handling, damage and waste.

The designer will need to be aware of the manual handling regulations and ensure appropriate lifting equipment is available to unload and move the pallets. Petrarch should never be lifted flat unless supported on a timber pallet.

If required to store for longer periods, Petrarch should be stored in closed rooms under normal climatic conditions and away from damp areas. Panels must be stacked horizontally on flat, stable supports and supporting panels. The goods must lay completely flat and be covered.

Incorrect storage can lead to permanent deformation of the panels. Climate differences on the two surfaces of a panel are to be avoided.

With pre-installed fastening elements such as panel hangers or preformed corners special care is to be taken that the climatic effect is uniform on all sides. Use intermediate layers of wood or plastic to avoid applying any loads onto these elements.

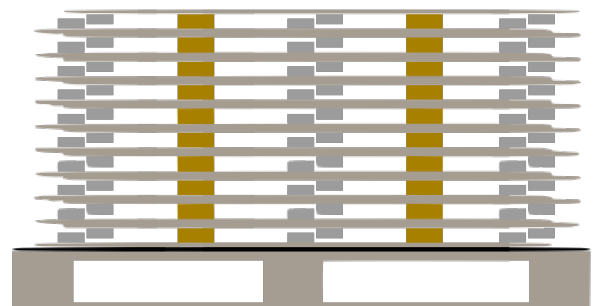

5.4 Workmanship

When cutting and drilling Petrarch on site, all electrically powered equipment should be operated in accordance with the manufacturer's instructions. When cutting and drilling Petrarch panels a respiratory mask and eye protection should be worn. Equipment should be to the relevant standard / regulation.

Cutting

Site cutting is best carried out with an electrically operated circular saw, the sheets should be clamped, face side uppermost, to a flat surface and a guide rail used to ensure true and straight cutting. For large amounts of site cutting a diamond tipped blade will often prove to be more economical than the abrasive cutting disc. Note: Petrarch Riven, features the directional surface of the original slate master. When cutting Petrarch Riven, the direction should always be considered.

In the factory our blades are:

- 300mm Diameter
- 30mm Bore to suit our saw
- 3.0mm thick
- 18 Gullets each 13mm deep
- 44/60 diamond electro plated around perimeter, 6mm down either edge
- Saw runs at 4000 RPM

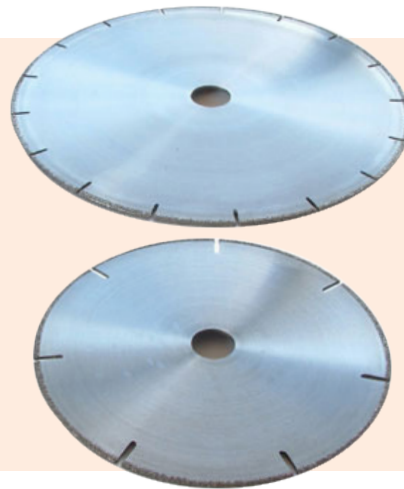

Drilling

Normal site drilling can be carried out using a handheld electric drill fitted with a masonry tungsten carbide bit. Drilling speeds in the region of 1800 rev/min.

Apertures

Rectangle / Square - Drill four corners and then cut the material out.

Hole - use tungsten carbide core drill to required perforation diameter.

Oval - use tungsten carbide core drill to diameter required and then either overlap perforations or cut the material out.

Please follow above cutting and drilling recommendations when carrying out on site apertures.

Edge Polishing

Even though Petrarch is homogeneous and through coloured, after cutting darker coloured panels, the edge will appear to be lighter than the face of the panel. An exposed edge (for example at a corner detail) can be polished using a wet and dry abrasive pad with water. This will remove saw marks and restore the edge to the main body colour.

5.5 Petrarch Cleaning Instruction

Petrarch is non-absorbent and will not, in normal circumstances, pick up atmospheric dirt. Nevertheless, during fixing or subsequently during building alterations, building site dirt and dust can contaminate the surface. The following lists the most common contaminants and the recommended course of action for cleaning.

Petrarch Cutting Dust

Best removed prior to fixing the panel; for standard finish panels, wash down the panel using a sponge or brush with hot soapy water and finally rinse with clean water.

Petrarch Drilling Dust

On the occasions when it is necessary to drill the panel on site, it is important to clean down the panel prior to it being installed. For standard finish panels this should be done using a sponge or brush with hot soapy water and a final rinse with clean water.

Shot-Blasted Panels

When supplying matt finish panels, the shot blasting process can leave a small amount of dust on surface. On a standard rainscreen application, panels will be naturally cleaned. Alternatively, or when used on internal applications, panels can be easily washed down either before or after being fitted following above-mentioned cleaning guidelines.

Splashes of Plaster and Concrete

These are most easily removed before the plaster or cement has set. To clean simply hose off with a jet of water and finally wipe down with a clean cloth.

Paints

Again, these are best removed when the paint is wet, using the appropriate solvent to the affected area and when softening occurs scrub the affected area with a nylon brush. It may be necessary to repeat this several times before all the paint is removed. Afterwards thoroughly scrub the panel using hot soapy water and rinse with clean water. In no circumstances should paint stripper be used as these can permanently stain the Petrarch.

Tar, Creosote, Grease, Lacquer, Paint

Clean the affected area with an appropriate solvent and if necessary, scrub with a nylon brush. Finally wash down with hot soapy water and rinse with clean water.

Pen, Pencil, Crayon

Use hot soapy water and scrub down with a nylon brush, finally rinse with clean water.

Cleaning Interval after Installation

The location of the building can determine the frequency that cleaning of the cladding panels is required. As a guide this is usually between 2-5 years by a specialist company. It is not recommended to use a high-pressure cleaner at close range as this can leave marks on the cladding. It is also not advised to use chemicals other than a mild detergent mixed with warm water when necessary.

GET IN TOUCH

E: info@petrarchpanels.com

T: +44(0)1424 852 641

www.petrarchpanels.com



PETRARCH

5 WAINWRIGHT CLOSE, CHURCHFIELDS INDUSTRIAL ESTATE
SAINT LEONARDS-ON-SEA, EAST SUSSEX, TN38 9PP

Petrarch Ltd. reserves the right to make substitutions and modifications to the specifications of any of its products without prior notice. It is the customer's responsibility to ensure that the company's products are correctly installed and that they are suitable for the customer's particular requirements and application.

Petrarch Ltd. undertakes business only on its standard terms and conditions.

For Project specific samples and technical assistance please contact our technical department on **info@petrarchpanels.com**

All information is correct as of the date of this document created January 2025