

PETRARCH FACE FASTENED SYSTEM

1. COVER PAGE
2. BASE DETAIL
3. TYPICAL HORIZONTAL JOINT
4. OPTIONAL HORIZONTAL JOINT DETAIL BIRDS BEAK PROFILE (OPTIONAL)
5. TYPICAL HORIZONTAL JOINT AND RAIL JOINT DETAIL
6. OPTIONAL HORIZONTAL JOINT AND RAIL JOINT DETAIL
7. COPING DETAIL
8. TYPICAL VERTICAL JOINT DETAIL
- 8A. OPTIONAL VERTICAL JOINT DETAIL (MARTLET JOINT)
9. INTERMEDIATE SUPPORT DETAIL
10. OUTSIDE CORNER DETAIL (OPEN CORNER)
11. OUTSIDE CORNER DETAIL (CLOSED CORNER)
12. OUTSIDE CORNER DETAIL (SQUARED CORNER)
13. OUTSIDE CORNER DETAIL (CHAMFERED CORNER)
14. OUTSIDE CORNER DETAIL (2MM BIRDS BEAK MITRE CORNER)
15. INSIDE CORNER DETAIL
16. WINDOW SILL DETAIL
17. WINDOW HEAD DETAIL
18. WINDOW JAMB DETAIL
19. WINDOW JAMB DETAIL (CANTILEVERED)
20. PETRARCH FACE FASTENING GUIDELINES
21. RAILS

SUBSTRATE: VARIES

INSULATION: BY OTHERS (ALL)

CLADDING: PETRARCH PANEL

DATE: 09-02-2021

GIRT ORIENTATION: VERTICAL

COVER PAGE

NOT TO SCALE

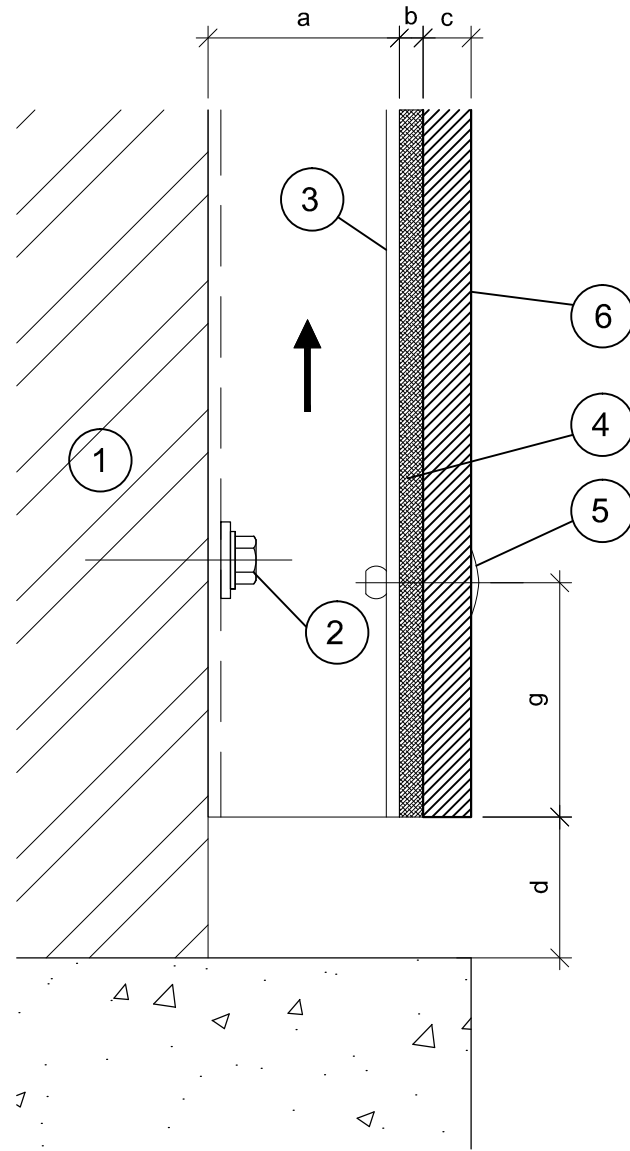

Items	
1	Substrate (By Others)
2	Primary fixing will vary subject to substrate composition
3	Aluminum or Steel sub-framing
4	Foam tape -refer to manufacturers instructions $\frac{1}{8}$ "(Optional)
5	Color Rivets to match panels
6	Petrarch Cladding panel

Dimensions	
a	1" (25mm)
b	$\frac{1}{8}$ " Foam tape (optional)
c	$\frac{1}{4}$ " Panel nominal thickness (7 mm)
d	2" to grade. $\frac{3}{4}$ " from flashing or concrete base condition
g	2"-3" c.o.fastener to edge of panel

* Note! dimension may vary due to the shimming requirement for plumbing and alignment of rails

SUBSTRATE: VARIES

INSULATION: BY OTHERS (ALL)

CLADDING: PETRARCH PANEL

DATE: 09-02-2021

GIRT ORIENTATION: VERTICAL

BASE DETAIL

NOT TO SCALE

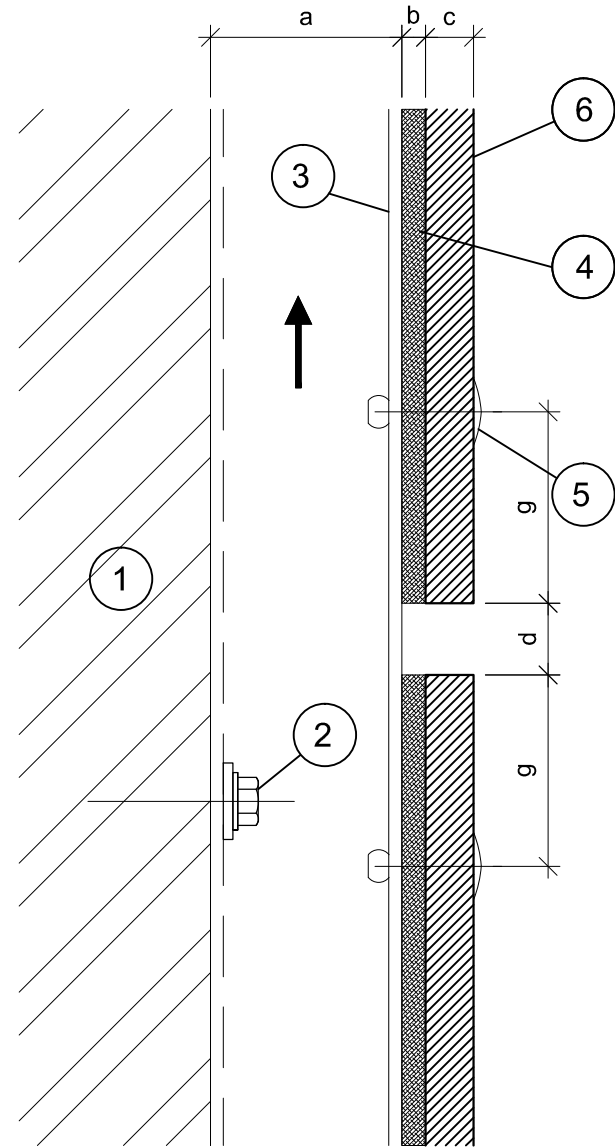

Items	
1	Substrate (By Others)
2	Primary fixing will vary subject to substrate composition
3	Aluminum or Steel sub-framing
4	Foam tape -refer to manufacturers instructions $\frac{1}{8}$ "(Optional)
5	Color Rivets to match panels
6	Petrarch Cladding panel

Dimensions	
a	1" (25mm)
b	$\frac{1}{8}$ " Foam tape (optional)
c	$\frac{1}{4}$ " Panel nominal thickness (7 mm)
d	$\frac{3}{8}$ " Panel joint
g	2"-3" c.o.fastener to edge of panel

* Note! dimension may vary due to the shimming requirement for plumbing and alignment of rails

SUBSTRATE: VARIES

INSULATION: BY OTHERS (ALL)

CLADDING: PETRARCH PANEL

DATE: 09-02-2021

GIRT ORIENTATION: VERTICAL

TYPICAL HORIZONTAL JOINT DETAIL

NOT TO SCALE

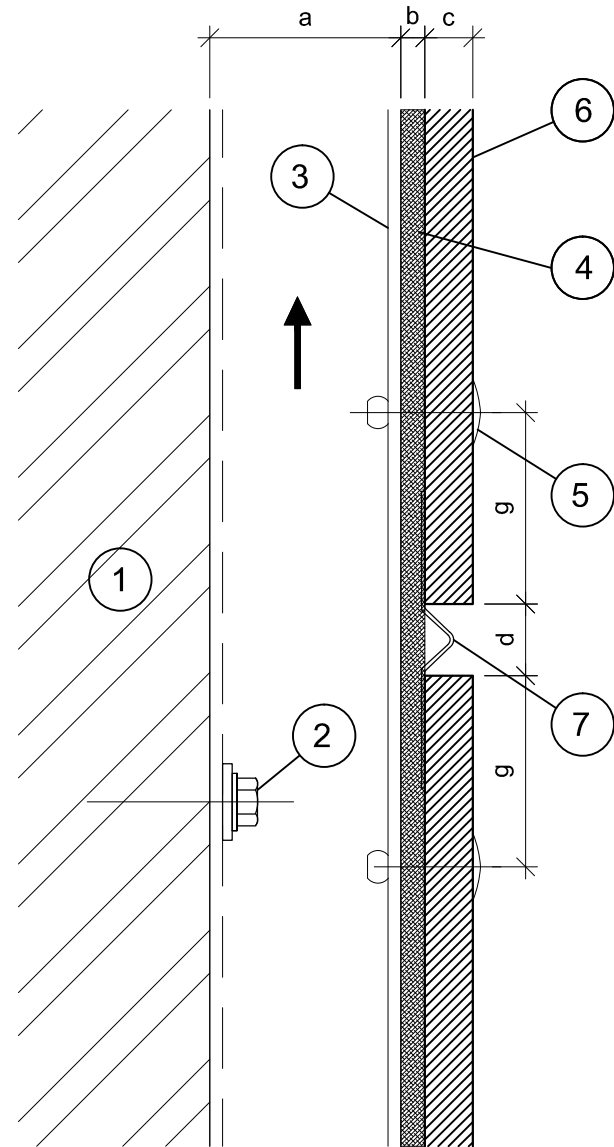

OPTIONAL DETAIL

Items	
1	Substrate (By Others)
2	Primary fixing will vary subject to substrate composition
3	Aluminum or Steel sub-framing
4	Foam tape -refer to manufacturers instructions $\frac{1}{8}$ "(Optional)
5	Color Rivets to match panels
6	Petrarch Cladding panel
7	Birds Beak Profile (Optional)

Dimensions	
a	1" (25mm)
b	$\frac{1}{8}$ " Foam tape (optional)
c	$\frac{1}{4}$ " Panel nominal thickness (7 mm)
d	$\frac{3}{8}$ " Panel joint
g	2"-3" c.o.fastener to edge of panel

* Note! dimension may vary due to the shimming requirement for plumbing and alignment of rails

SUBSTRATE: VARIES

INSULATION: BY OTHERS (ALL)

CLADDING: PETRARCH PANEL

DATE: 09-02-2021

GIRT ORIENTATION: VERTICAL

OPTIONAL HORIZONTAL JOINT DETAIL

NOT TO SCALE

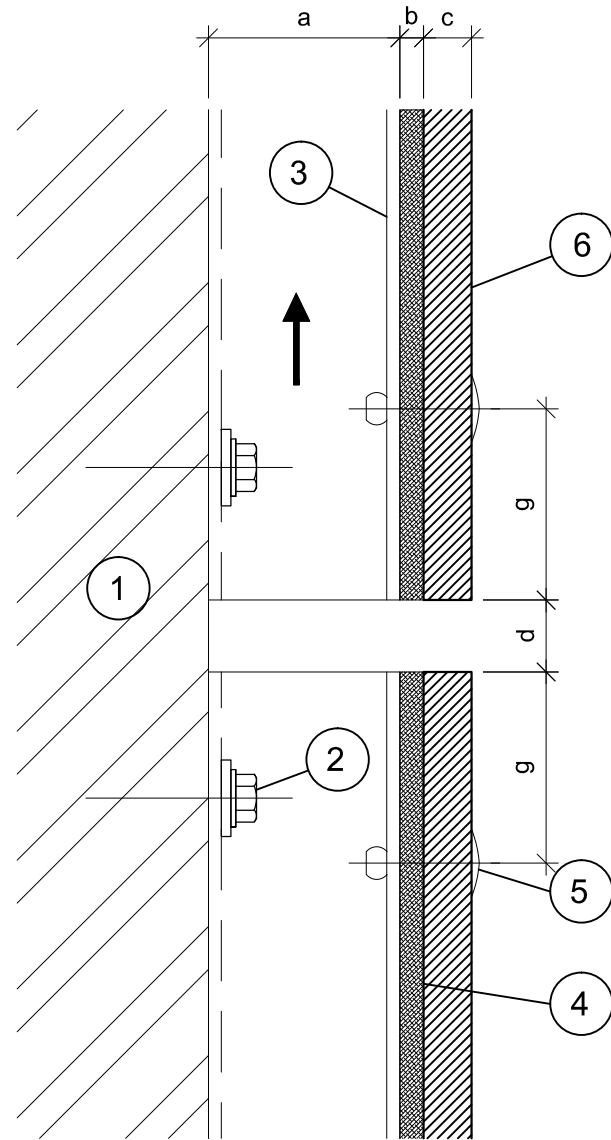

Items	
1	Substrate (By Others)
2	Primary fixing will vary subject to substrate composition
3	Aluminum or Steel sub-framing
4	Foam tape -refer to manufacturers instructions $\frac{1}{8}$ "(Optional)
5	Color Rivets to match panels
6	Petrarch Cladding panel

Dimensions	
a	1" (25mm)
b	$\frac{1}{8}$ " Foam tape (optional)
c	$\frac{1}{4}$ " Panel nominal thickness (7 mm)
d	$\frac{3}{8}$ " Panel Joint
g	2"-3" c.o.fastener to edge of panel

* Note! dimension may vary due to the shimming requirement for plumbing and alignment of rails

SUBSTRATE: VARIES

INSULATION: BY OTHERS (ALL)

CLADDING: PETRARCH PANEL

DATE: 09-02-2021

GIRT ORIENTATION: VERTICAL

TYPICAL HORIZONTAL JOINT AND RAIL JOINT DETAIL

NOT TO SCALE

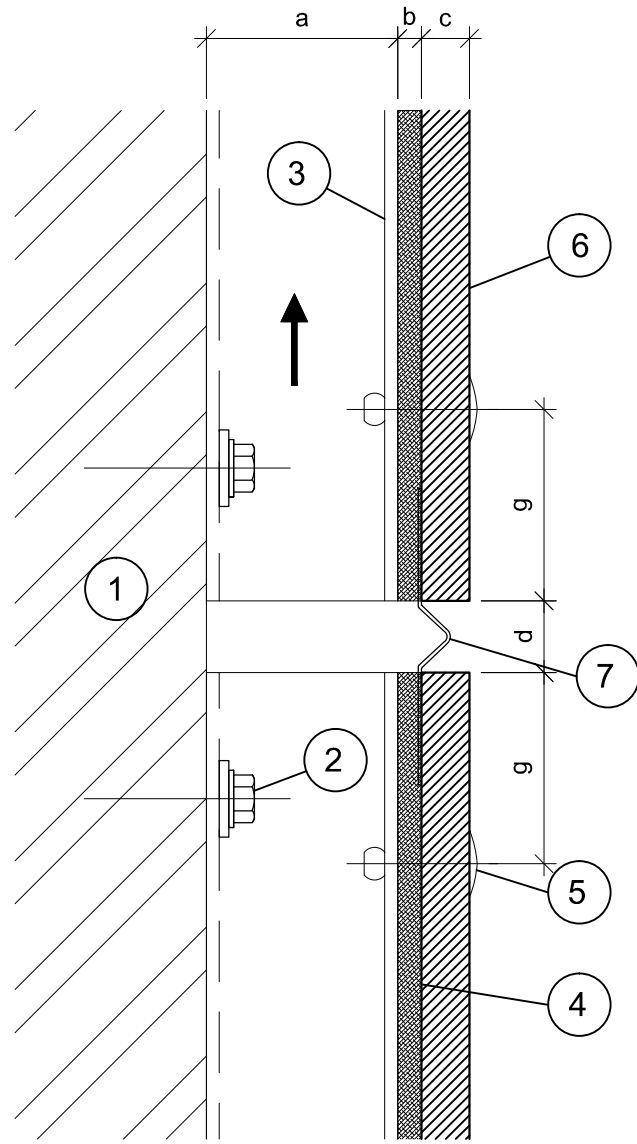

OPTIONAL DETAIL

Items	
1	Substrate (By Others)
2	Primary fixing will vary subject to substrate composition
3	Aluminum or Steel sub-framing
4	Foam tape -refer to manufacturers instructions 1/8"(Optional)
5	Color Rivets to match panels
6	Petrarch Cladding panel
7	Birds Beak Profile (Optional)

Dimensions	
a	1" (25mm)
b	1/8" Foam tape (optional)
c	1/4" Panel nominal thickness (7 mm)
d	3/8" Panel Joint
g	2"-3" c.o.fastener to edge of panel

* Note! dimension may vary due to the shimming requirement for plumbing and alignment of rails

SUBSTRATE: VARIES

INSULATION: BY OTHERS (ALL)

CLADDING: PETRARCH PANEL

DATE: 09-02-2021

GIRT ORIENTATION: VERTICAL

OPTIONAL HORIZONTAL JOINT AND RAIL JOINT DETAIL

6

NOT TO SCALE

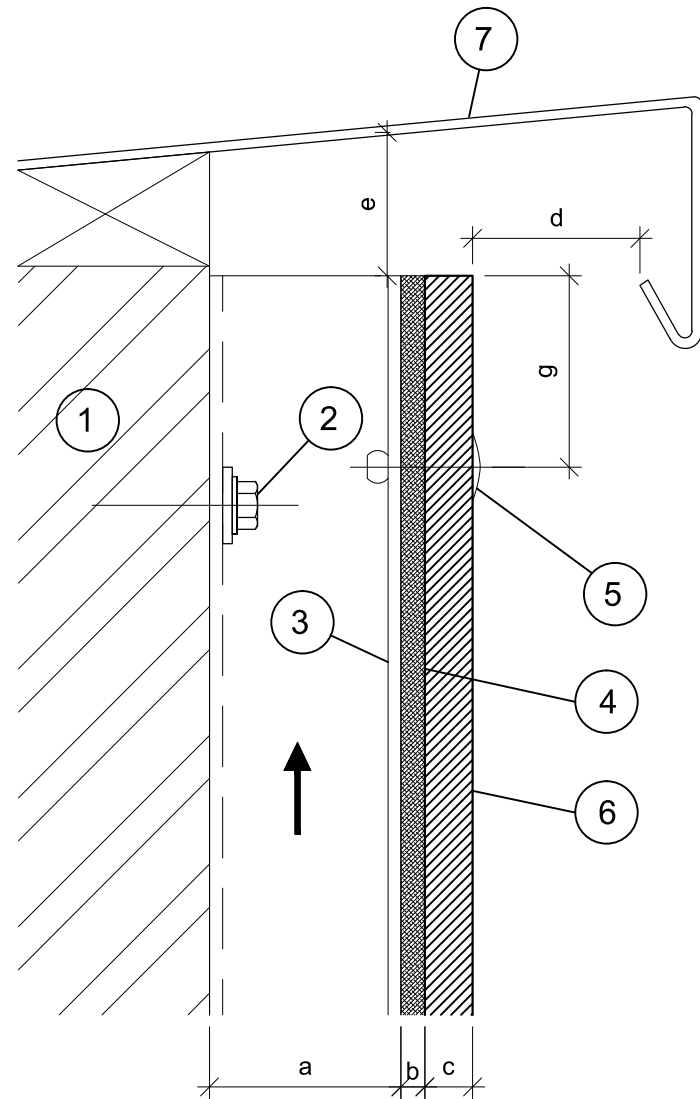

Items	
1	Substrate (By Others)
2	Primary fixing will vary subject to substrate composition
3	Aluminum or Steel sub-framing
4	Foam tape -refer to manufacturers instructions $\frac{1}{8}$ "(Optional)
5	Color Rivets to match panels
6	Petrarch Cladding panel
7	Coping detail to project requirement (By Others)

Dimensions	
a	1" (25mm)
b	$\frac{1}{8}$ " Foam tape (optional)
c	$\frac{1}{4}$ " Panel nominal thickness (7 mm)
d	$\frac{3}{4}$ " Panel to flashing distance
e	$\frac{3}{4}$ " Distance
g	2"-3" c.o.fastener to edge of panel

* Note! dimension may vary due to the shimming requirement for plumbing and alignment of rails

SUBSTRATE: VARIES

INSULATION: BY OTHERS (ALL)

CLADDING: PETRARCH PANEL

DATE: 09-02-2021

GIRT ORIENTATION: VERTICAL

COPING DETAIL

NOT TO SCALE

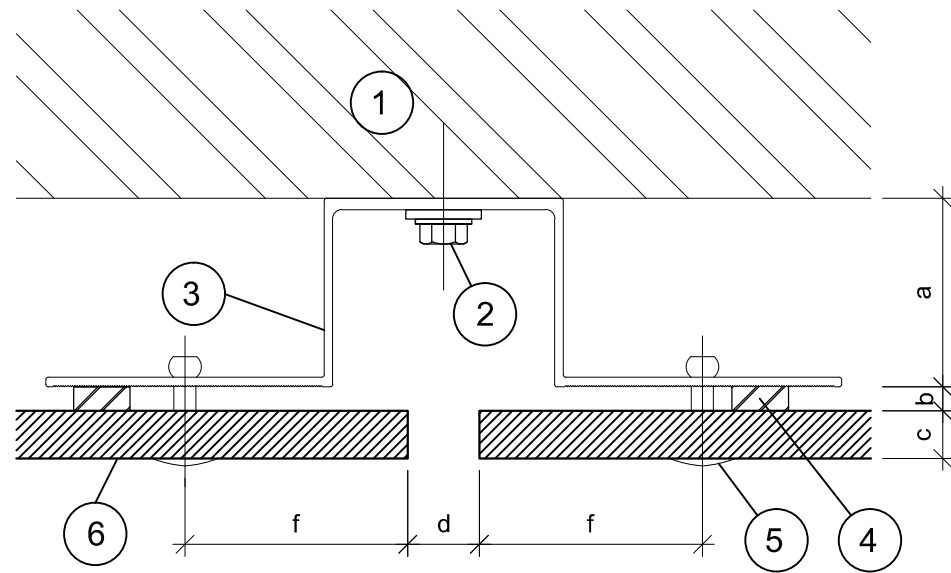

Items	
1	Substrate (By Others)
2	Primary fixing will vary subject to substrate composition
3	Aluminum or Steel sub-framing
4	Foam tape -refer to manufacturers instructions $\frac{1}{8}$ "(Optional)
5	Color Rivets to match panels
6	Petrarch Cladding panel

Dimensions	
a	1" (25mm)
b	$\frac{1}{8}$ " Foam tape (optional)
c	$\frac{1}{4}$ " Panel nominal thickness (7 mm)
d	$\frac{3}{8}$ " Panel joint
f	1"-2" c.o.fastener to edge of panel

* Note! dimension may vary due to the shimming requirement for plumbing and alignment of rails

SUBSTRATE: VARIES

INSULATION: BY OTHERS (ALL)

CLADDING: PETRARCH PANEL

DATE: 09-02-2021

GIRT ORIENTATION: VERTICAL

TYPICAL VERTICAL JOINT DETAIL

NOT TO SCALE

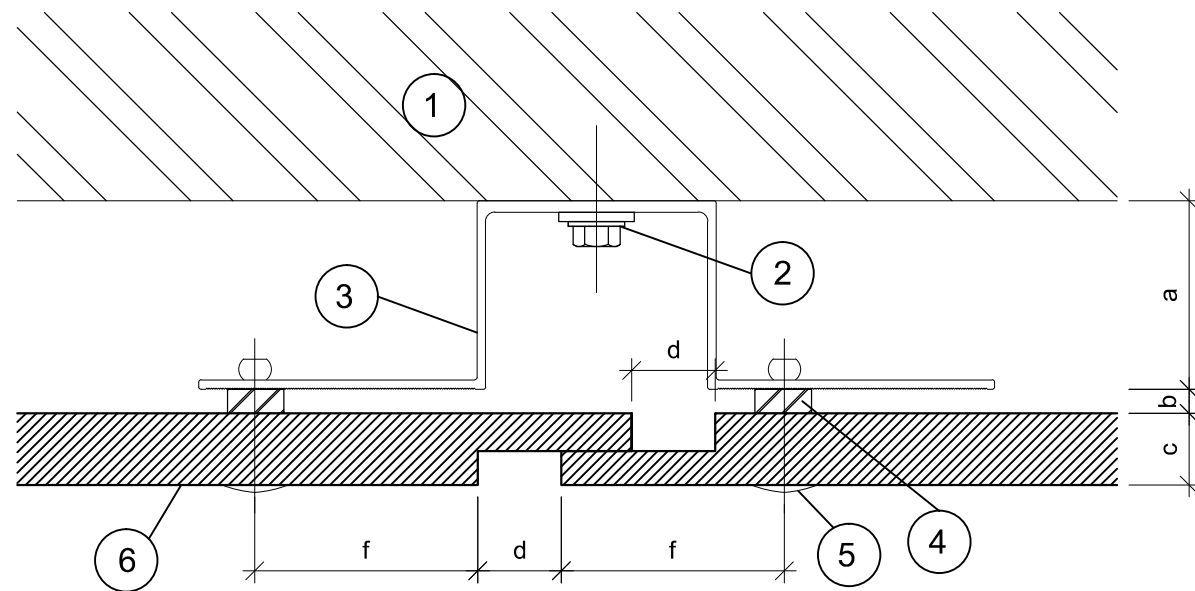
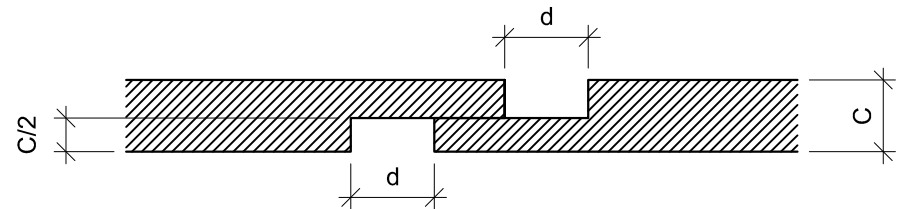

OPTIONAL DETAIL (APPLICABLE IN 10 MM PANELS ONLY)

Items	
1	Substrate (By Others)
2	Primary fixing will vary subject to substrate composition
3	Aluminum or Steel sub-framing
4	Foam tape -refer to manufacturers instructions 1/8"(Optional)
5	Color Rivets to match panels
6	Petrarch Cladding panel

Dimensions	
a	1" (25mm)
b	1/8" Foam tape (optional)
c	3/8" Panel nominal thickness (10 mm)
d	3/8" Panel joint
f	1"-2" c.o.fastener to edge of panel

* Note! dimension may vary due to the shimming requirement for plumbing and alignment of rails

SUBSTRATE: VARIES

INSULATION: BY OTHERS (ALL)

CLADDING: PETRARCH PANEL

DATE: 09-02-2021

GIRT ORIENTATION: VERTICAL

OPTIONAL VERTICAL JOINT DETAIL (MARTLET JOINT)

8A

NOT TO SCALE

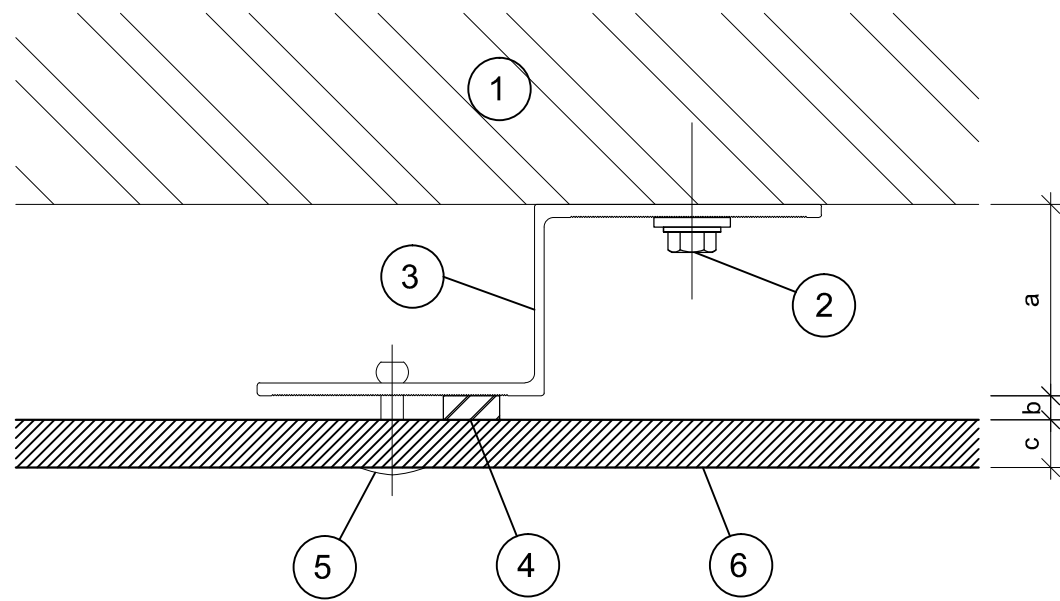

Items	
1	Substrate (By Others)
2	Primary fixing will vary subject to substrate composition
3	Aluminum or Steel sub-framing
4	Foam tape -refer to manufacturers instructions $\frac{1}{8}$ "(Optional)
5	Color Rivets to match panels
6	Petrarch Cladding panel

Dimensions	
a	1" (25mm)
b	$\frac{1}{8}$ " Foam tape (optional)
c	$\frac{1}{4}$ " Panel nominal thickness (7 mm)

* Note! dimension may vary due to the shimming requirement for plumbing and alignment of rails

SUBSTRATE:VARIES

INSULATION: BY OTHERS (ALL)

CLADDING: PETRARCH PANEL

DATE: 09-02-2021

GIRT ORIENTATION: VERTICAL

INTERMEDIATE SUPPORT DETAIL

NOT TO SCALE

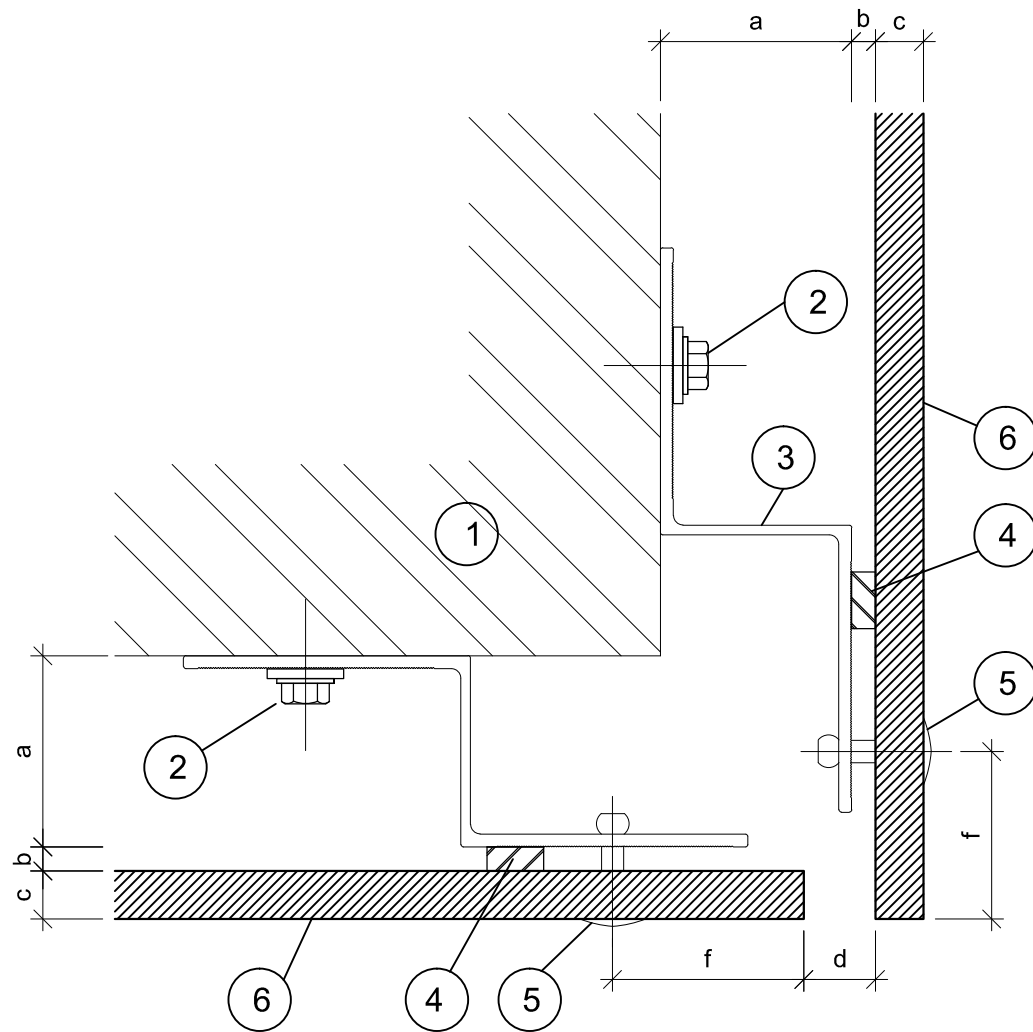

Items	
1	Substrate (By Others)
2	Primary fixing will vary subject to substrate composition
3	Aluminum or Steel sub-framing
4	Foam tape -refer to manufacturers instructions $\frac{1}{8}$ "(Optional)
5	Color Rivets to match panels
6	Petrarch Cladding panel

Dimensions	
a	1" (25mm)
b	$\frac{1}{8}$ " Foam tape (optional)
c	$\frac{1}{4}$ " Panel nominal thickness (7 mm)
d	$\frac{3}{8}$ " Panel joint
f	1"-2" c.o.fastener to edge of panel

* Note! dimension may vary due to the shimming requirement for plumbing and alignment of rails

SUBSTRATE: VARIES

INSULATION: BY OTHERS (ALL)

CLADDING: PETRARCH PANEL

DATE: 09-02-2021

GIRT ORIENTATION: VERTICAL

OUTSIDE CORNER DETAIL (OPEN CORNER)

NOT TO SCALE

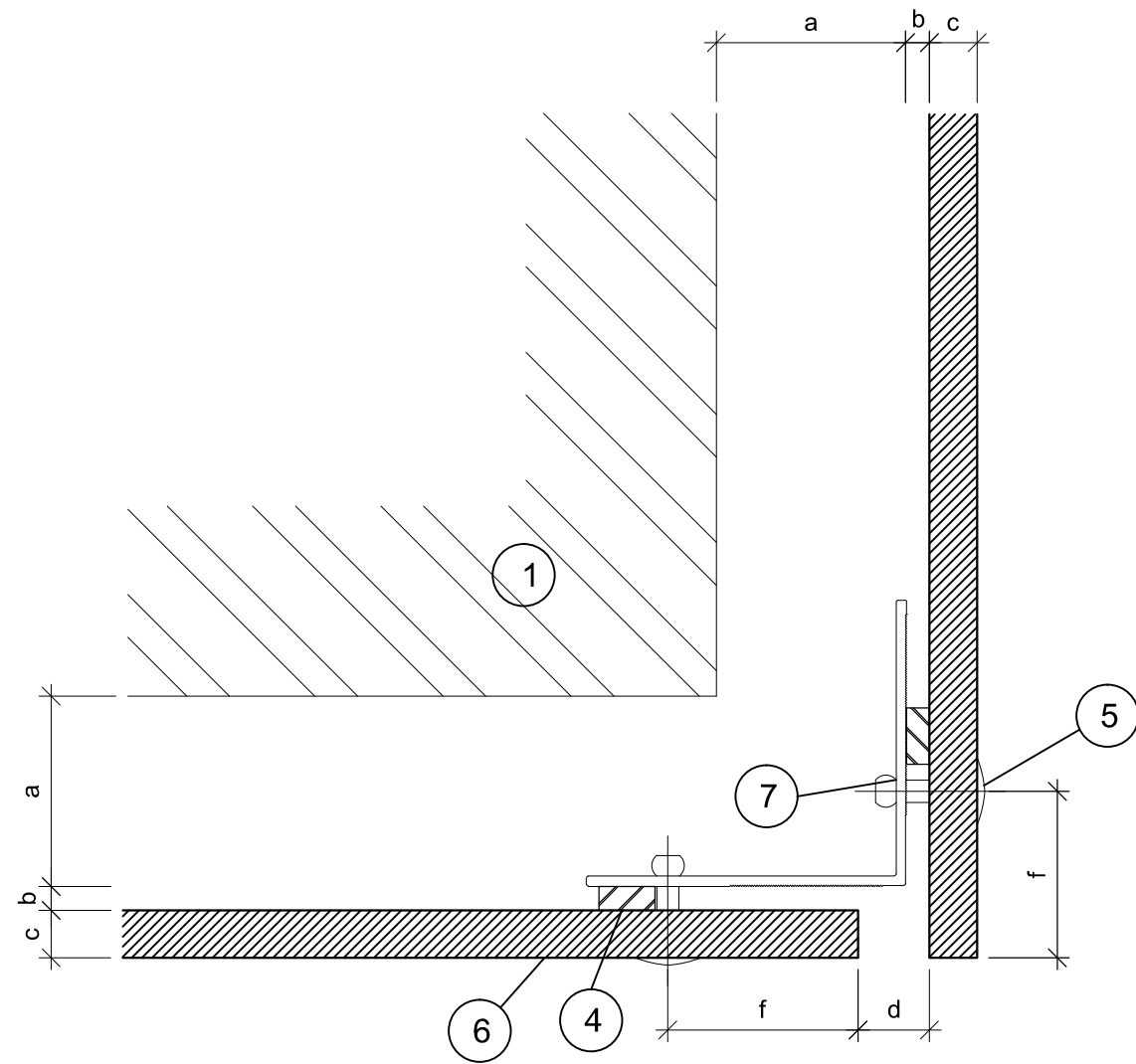

OPTIONAL DETAIL

Items	
1	Substrate (By Others)
4	Foam tape -refer to manufacturers instructions $\frac{1}{8}$ "(Optional)
5	Color Rivets to match panels
6	Petrarch Cladding panel
7	Prefinished L-angle

Dimensions	
a	1" (25mm)
b	$\frac{1}{8}$ " Foam tape (optional)
c	$\frac{1}{4}$ " Panel nominal thickness (7 mm)
d	$\frac{3}{8}$ " Panel joint
f	1"-2" c.o.fastener to edge of panel

* Note! dimension may vary due to the shimming requirement for plumbing and alignment of rails

SUBSTRATE: VARIES

INSULATION: BY OTHERS (ALL)

CLADDING: PETRARCH PANEL

DATE: 09-02-2021

GIRT ORIENTATION: VERTICAL

OUTSIDE CORNER DETAIL (CLOSED CORNER)

NOT TO SCALE

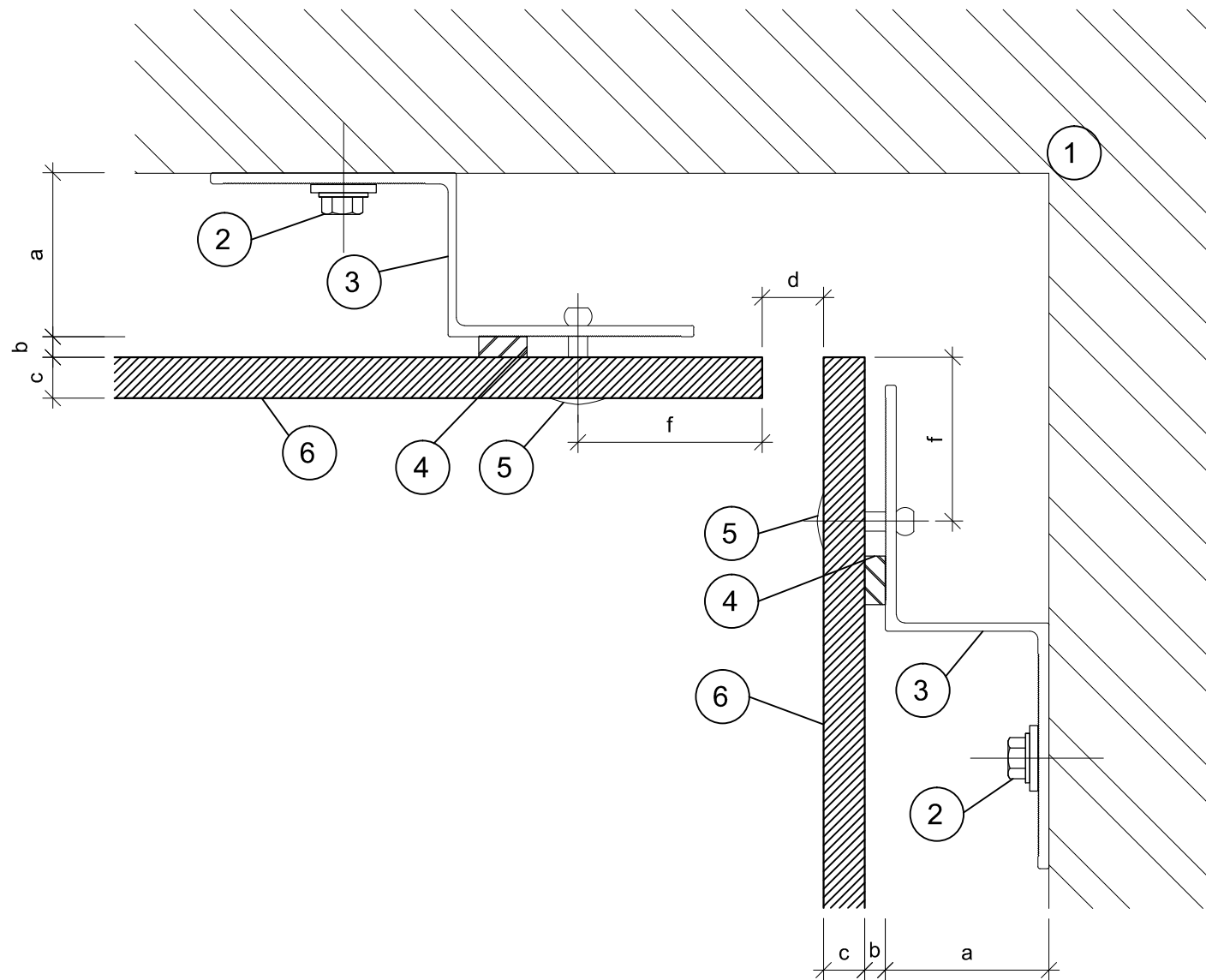

Items	
1	Substrate (By Others)
2	Primary fixing will vary subject to substrate composition
3	Aluminum or Steel sub-framing
4	Foam tape -refer to manufacturers instructions $\frac{1}{8}$ "(Optional)
5	Color Rivets to match panels
6	Petrarch Cladding panel

Dimensions	
a	1" (25mm)
b	$\frac{1}{8}$ " Foam tape (optional)
c	$\frac{1}{4}$ " Panel nominal thickness (7 mm)
d	$\frac{3}{8}$ " Panel joint
f	1"-2" c.o.fastener to edge of panel

* Note! dimension may vary due to the shimming requirement for plumbing and alignment of rails

SUBSTRATE: VARIES

INSULATION: BY OTHERS (ALL)

CLADDING: PETRARCH PANEL

DATE: 09-02-2021

GIRT ORIENTATION: VERTICAL

INSIDE CORNER DETAIL

NOT TO SCALE

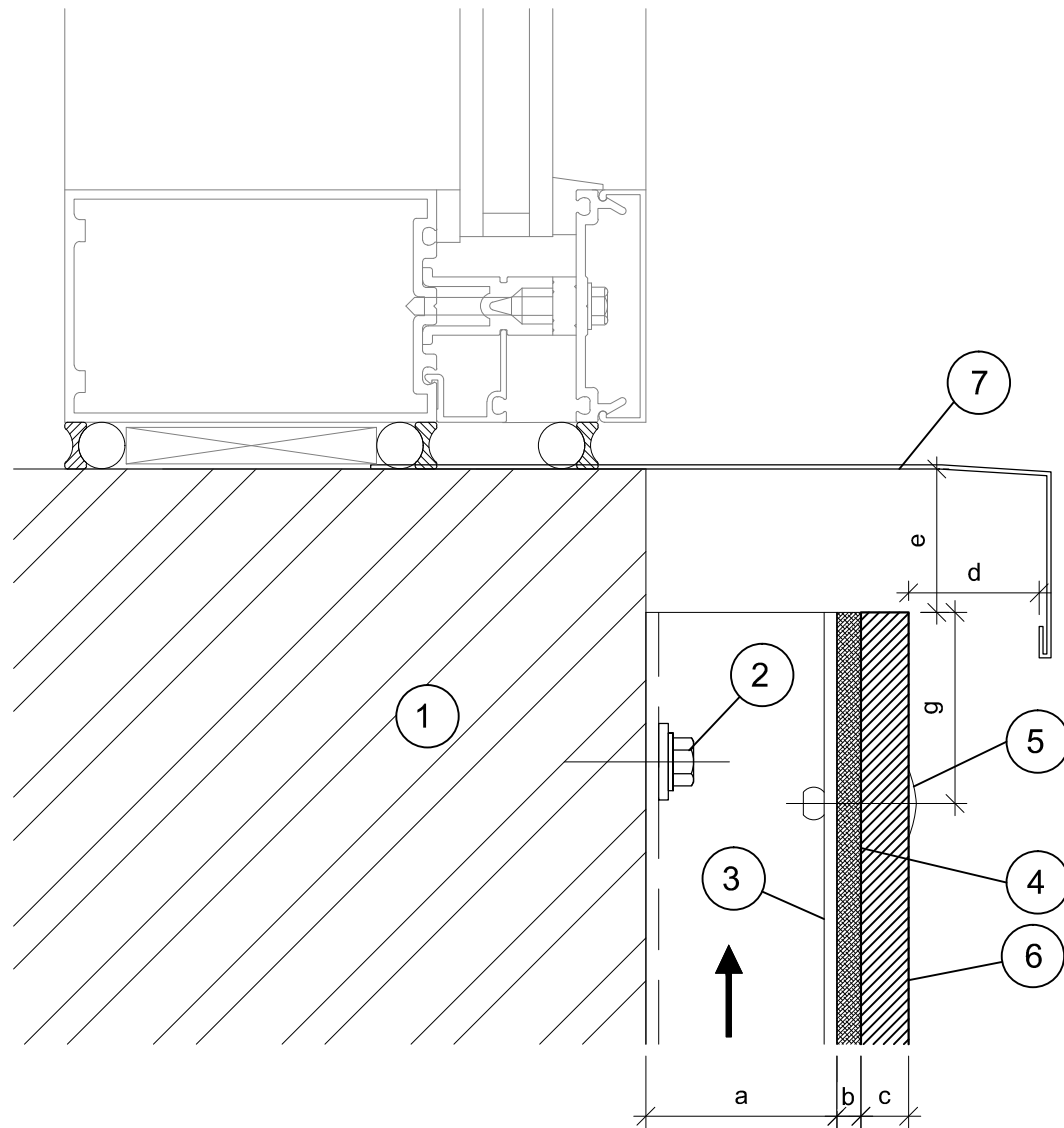

Items	
1	Substrate (By Others)
2	Primary fixing will vary subject to substrate composition
3	Aluminum or Steel sub-framing
4	Foam tape -refer to manufacturers instructions $\frac{1}{8}$ "(Optional)
5	Color Rivets to match panels
6	Petrarch Cladding panel
7	Window detail to project requirement (By Others)

Dimensions	
a	1" (25mm)
b	$\frac{1}{8}$ " Foam tape (optional)
c	$\frac{1}{4}$ " Panel nominal thickness (7 mm)
d	$\frac{3}{4}$ " Panel to flashing distance
e	$\frac{3}{4}$ " Distance
g	2"-3" c.o.fastener to edge of panel

* Note! dimension may vary due to the shimming requirement for plumbing and alignment of rails

SUBSTRATE: VARIES

INSULATION: BY OTHERS (ALL)

CLADDING: PETRARCH PANEL

DATE: 09-02-2021

GIRT ORIENTATION: VERTICAL

WINDOW SILL DETAIL

NOT TO SCALE

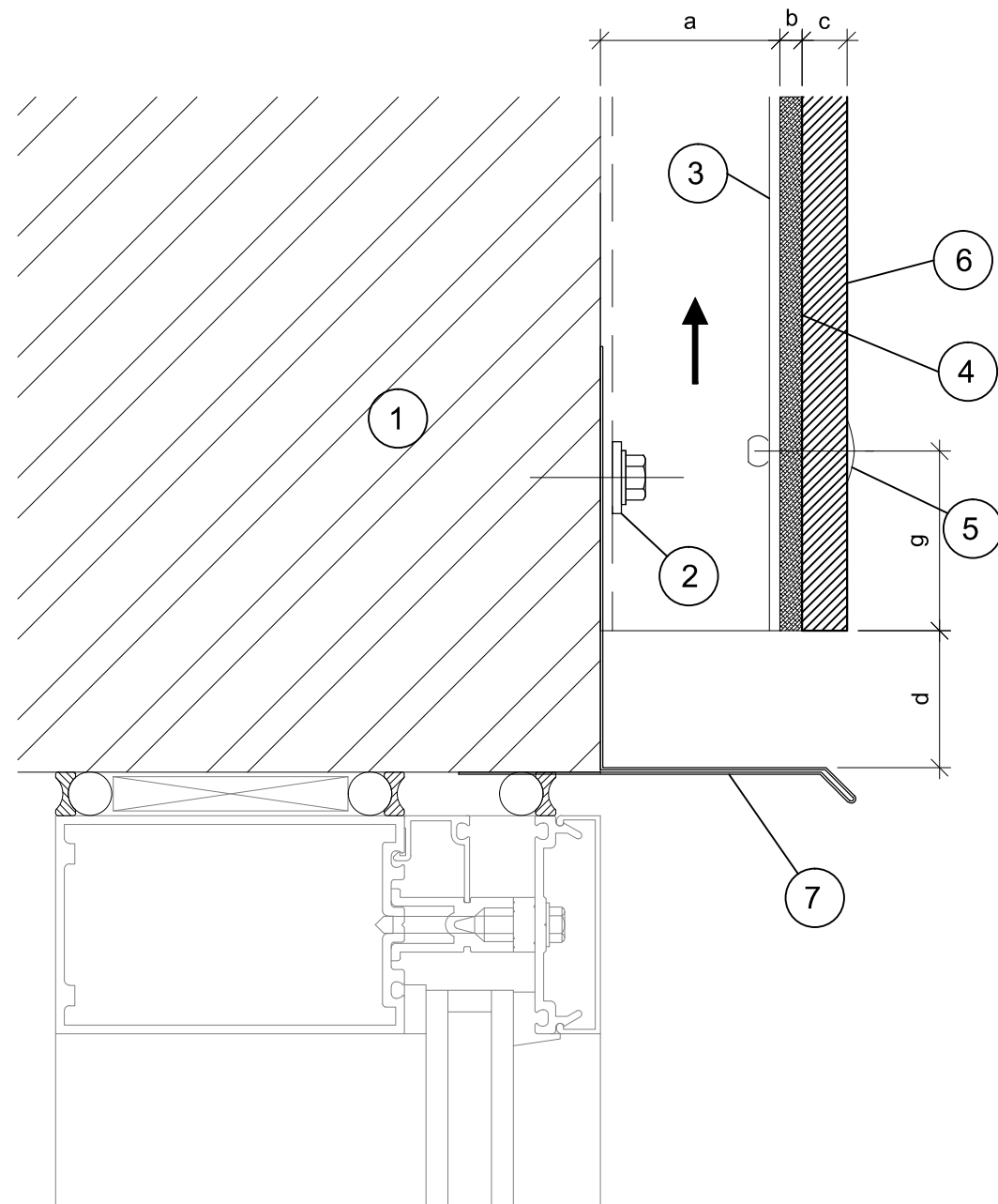

Items	
1	Substrate (By Others)
2	Primary fixing will vary subject to substrate composition
3	Aluminum or Steel sub-framing
4	Foam tape -refer to manufacturers instructions $\frac{1}{8}$ "(Optional)
5	Color Rivets to match panels
6	Petrarch Cladding panel
7	Window detail to project requirement (By Others)

Dimensions	
a	1" (25mm)
b	$\frac{1}{8}$ " Foam tape (optional)
c	$\frac{1}{4}$ " Panel nominal thickness (7 mm)
d	$\frac{3}{4}$ " Panel to flashing distance
g	2"-3" c.o.fastener to edge of panel

* Note! dimension may vary due to the shimming requirement for plumbing and alignment of rails

SUBSTRATE: VARIES

INSULATION: BY OTHERS (ALL)

CLADDING: PETRARCH PANEL

DATE: 09-02-2021

GIRT ORIENTATION: VERTICAL

WINDOW HEAD DETAIL

NOT TO SCALE

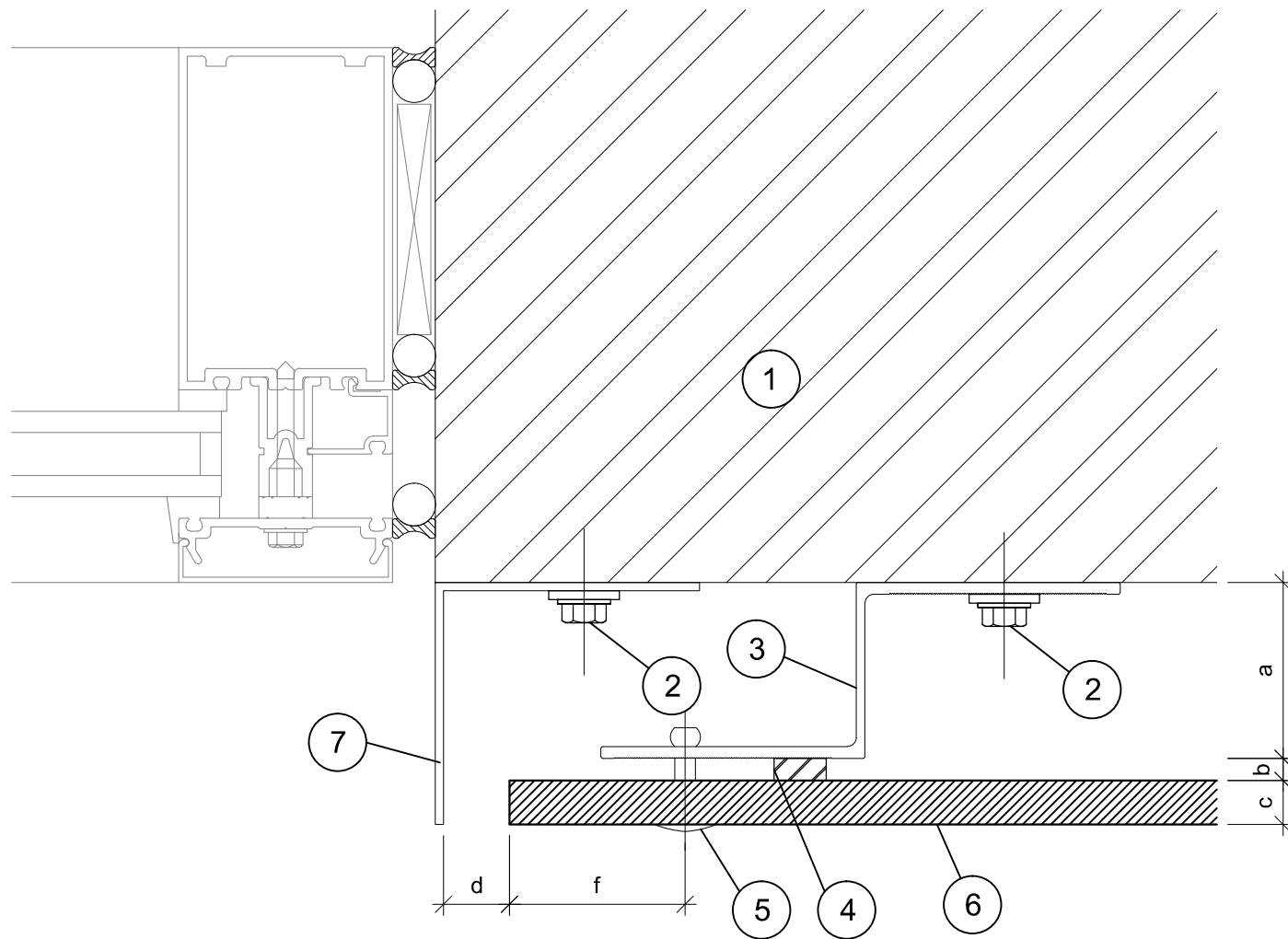

Items	
1	Substrate (By Others)
2	Primary fixing will vary subject to substrate composition
3	Aluminum or Steel sub-framing
4	Foam tape -refer to manufacturers instructions $\frac{1}{8}$ "(Optional)
5	Color Rivets to match panels
6	Petrarch Cladding panel
7	Window detail to project requirement (By Others)

Dimensions	
a	1" (25mm)
b	$\frac{1}{8}$ " Foam tape (optional)
c	$\frac{1}{4}$ " Panel nominal thickness (7 mm)
d	$\frac{3}{8}$ " Panel to flashing distance
f	1"-2" c.o.fastener to edge of panel

* Note! dimension may vary due to the shimming requirement for plumbing and alignment of rails

SUBSTRATE: VARIES

INSULATION: BY OTHERS (ALL)

CLADDING: PETRARCH PANEL

DATE: 09-02-2021

GIRT ORIENTATION: VERTICAL

WINDOW JAMB DETAIL

NOT TO SCALE

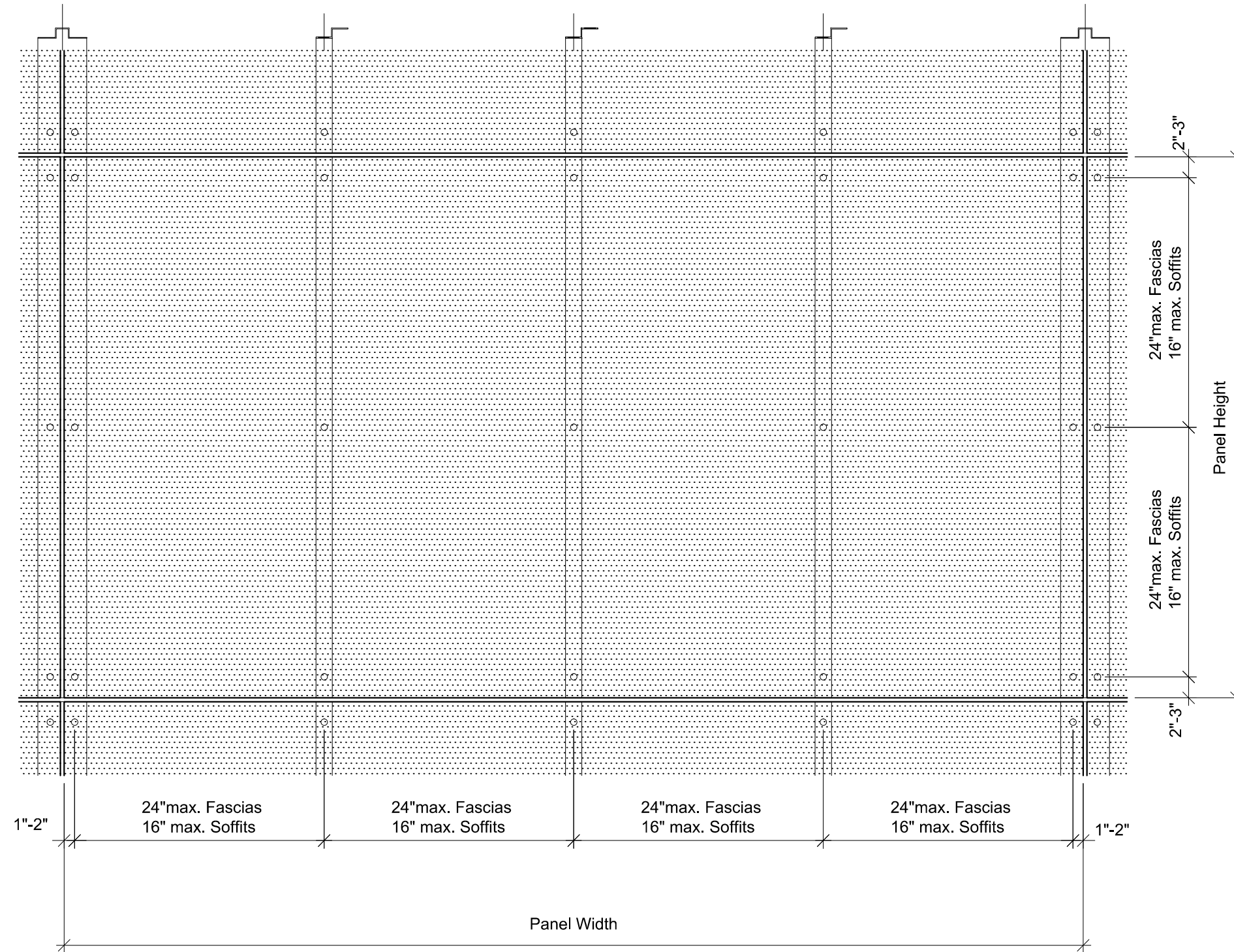

Face Fastening Guidelines

- Panels Should be drilled With one fixed point nearest to the center of the panel (FP-3/6") and all others as sliding point (SP-3/8")
- Holes in the subframe should all be fixed points (3/16") carried out using a centralizing tool
- Holes in the subframe should all be fixed points (3/16") carried out using a centralizing tool
- Rivets specification
 - **7mm Petrarch**-Large flange Al or S/S Ø 16mm (5/8") Head 4.8 (3-16")x18mm(45/64") (grip range 6.0: 12.5mm-15/64":31/64")
 - **10mm Petrarch**-Large flange Al or S/S Ø 16mm (5/8") Head 4.8 (3-16")x23mm(29/32") (grip range 11.0: 19.5mm-7/16":19/64")
- **Rivets Should always be installed using a Centralizing Tool and a Special Mouth Piece G3 Thread M10 X 11mm head allowing a0.3mm clearance for stress free mounting of the Rivets.**

SUBSTRATE: ---	INSULATION: ---
CLADDING:---	DATE: 09-02-2021
	GIRT ORIENTATION: ---

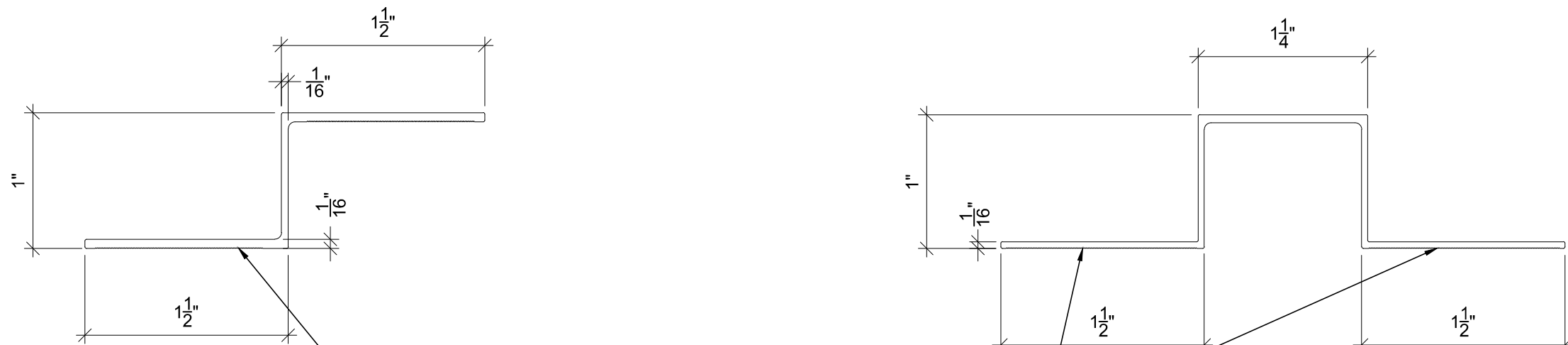

DIMENSIONS WILL VARY FROM VARIOUS PROVIDERS OF FRAMING. PLEASE CONFIRM FRAMING IS WIDE ENOUGH TO SUPPORT THE FASTENING PATTERN.

SUBSTRATE: ---

INSULATION: ---

CLADDING:---

DATE: 09-02-2021

GIRT ORIENTATION: ---

RAILS
NOT TO SCALE