



# FIXING INSTRUCTIONS

STENI Colour  
STENI Vision  
STENI Nature

FAÇADE PANELS MOUNTED AS VENTILATED CLADDING



LASTING EXPRESSIONS

## Before starting the installation

### PRODUCT INFORMATION ON THE PALLET

During storage, the pallets must be stored dry and covered, and placed on a flat surface.

Documents, product information and fixing instructions can be found on the pallet.

STENI Colour and STENI Vision are available in three different gloss levels. The pallet has additional marking which shows the gloss level of the panels on the pallet.

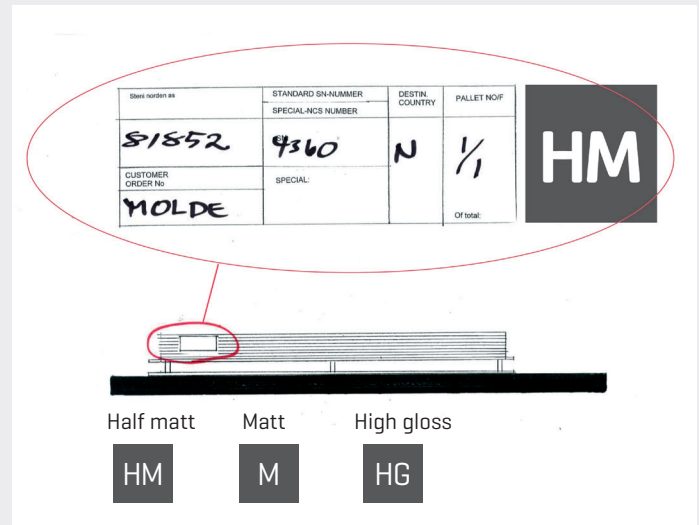

## Handling the panels

Pallets must always be strapped when transporting panels around the construction site.

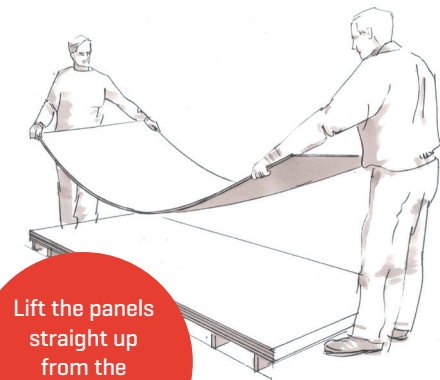
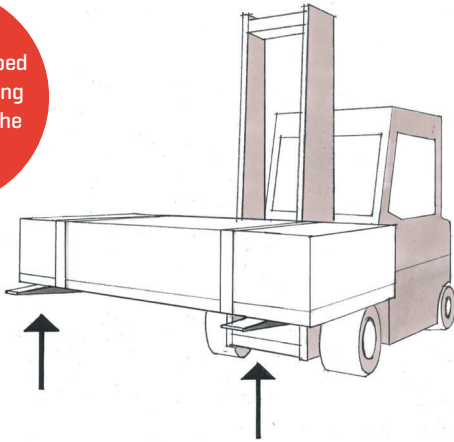

Lift the panels straight up from the pallet, without scratching.

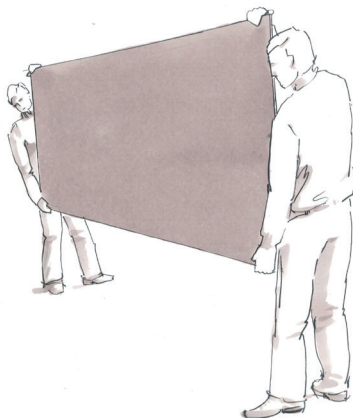

Carry the panels on their side.

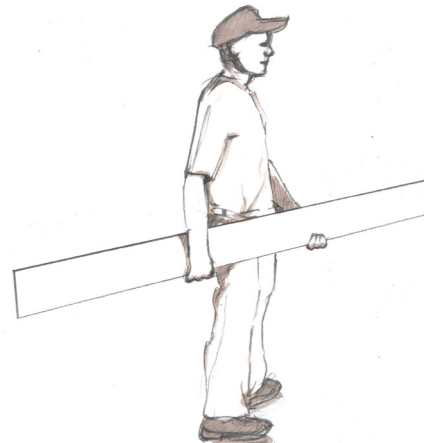

## Special provisions

### ACCEPTANCE CHECK TRANSPORTATION DAMAGE COMPLAINTS AND CLAIMS

Upon receipt, the buyer must check that the delivery corresponds to the delivery note. The buyer must, as far as possible, also unpack and perform a quality inspection of the goods. Any deviations in the delivery and visible damage to products and/or packaging must be reported on the delivery note.

Inspect all panels before reworking and mounting them. Any damage, flaws or defects on panels that have been mounted, cut, drilled or otherwise reworked after receipt are considered as accepted by the customer.

STENI AS must be notified of all flaws and defects without undue delay, no later than 14 days after the defect was discovered or should have been discovered, and in all cases before the product is taken into use.

STENI AS does not accept any claims as a result of transport damage or other damage unless these guidelines are followed.

Please refer to our product warranty.

### CERTIFICATIONS

STENI panels are certified according to the following:



Please refer to our website and the websites of the various certification bodies.

### ENVIRONMENT

- STENI panels are environmentally friendly and contain no hazardous substances.
- The product is approved for indoor use and satisfies requirements for indoor environments.
- The products are included in the Nordic Ecolabel building portal and approved for use in Ecolabelled buildings.
- In addition, STENI products are registered in BASTA, SundaHus and BVB, and there is an EPD for the products.
- More information is available on our website.



NEPD 0096E  
NEPD 0097E



**BYGGVARUBEDÖMNINGEN**

**SundaHus**

### CONTROL MEASUREMENTS AND TOLERANCES

**Take control measurements of the wall and the panels before mounting.**

The panels have a length/width tolerance of  $\pm 2$  mm. Edge thickness of  $\pm 1$  mm and diagonal tolerance of max. 3 mm. Any deviations in measurements should be distributed across several panels, so that the seams are even and continuous.

For panels that are pre-drilled at the factory, hole distance tolerance is  $\pm 5$  mm.

For elements, the angle tolerance is  $\pm 3$  degrees, measured 100 mm from the corner.

We reserve the right to make improvements and additions to these instructions without prior notice. [Ref. month published.]

### IMPORTANT INFORMATION

In order to satisfy the criteria for type approvals, fire approvals and warranty provisions, all the advice and instructions in the fixing guide must be followed carefully. You can download this from [www.steni.com](http://www.steni.com) or request a copy from STENI AS.

Using alternate methods may result in loss of warranty and damage to the products and underlying structures.

## Tips for a safe installation

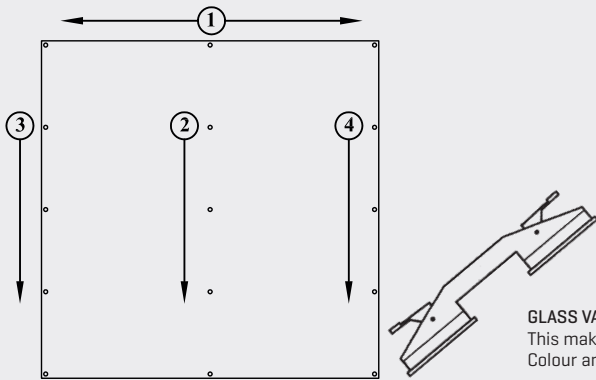

**SPACER BLOCK**  
When mounting a joint profile, it is a good idea to use a spacer block that has a groove for the joint profile.

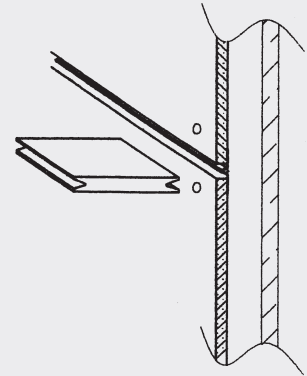

**GLASS VACUUM LIFTER**  
This makes it easier to handle STENI Colour and STENI Vision panels.

### SCREW PATTERN

Use a laser or other measuring tool to set horizontal and vertical reference lines on the façade before starting beginning the installation. The illustration shows the recommended screw pattern (follow the sequence 1-4)

## CUTTING AND DRILLING

Always cut STENI Colour and STENI Vision from the front side.  
Use a straightedge [cutting disc 1]. Speed: min. 3000 rpm.  
Always cut STENI Nature from the back side [cutting disc 2].  
For drilling, use a multi-construction drill bit.  
Use a hole diameter of Ø5.5 mm for STENI standard screws and pop rivets.  
The minimum distance from edge to hole is 15 mm.  
The distance between holes should be 220-300 mm [see figure]

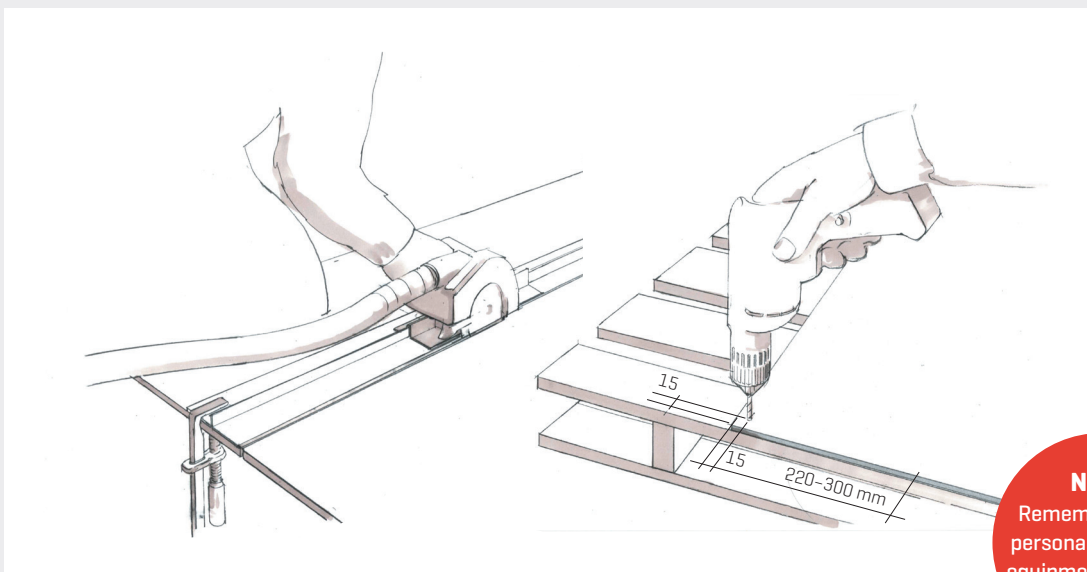
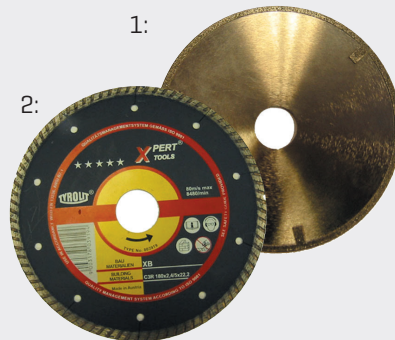

**Note:**  
Remember to use personal protective equipment. See HSE data sheet.

STENI recommends using a plunge saw / track saw with dust extraction.  
STENI cutting discs fit saws with spindle diameters of Ø30 mm Ø25.4 mm Ø22.2 mm Ø20 mm.  
Remember to enter the correct diameter when you place your order.

## Tips for a safe installation

### EDGE PAINT WITH EDGE PAINT MARKER

We recommend using an edge paint marker to paint cut surfaces after adjusting/cutting panels with edge paint.

The surface must be clean, dry, and free of dust, grease, oil and other contamination before application.

For best results, we recommend washing the cut surface with an alkaline cleaning agent (pH 9+) before using the edge paint marker.

Shake the pen well before use and periodically during use to ensure that the pigments in the ink are well distributed.

If you don't use a paint marker or you want a different colour on the edge, you can paint the edge with ordinary outdoor paint.

We recommend using a roller to apply the paint.

Note that the cut surface may have small pores and irregularities which, depending on the application method, may be difficult to cover with edge paint. These pores are not a defect in the product but occur naturally during production.

### BATTENING

STENI façade panels are mounted as ventilated cladding on wooden or metal battens. For optimal results, the battens must be mounted level and plumb. For more information on using battens, see pages 4 and 5.

Also see SINTEF Building and Infrastructure Design Guides 542.502 and 542.003

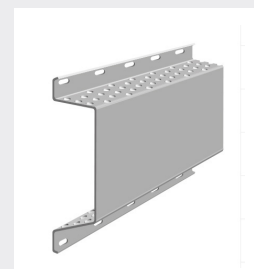
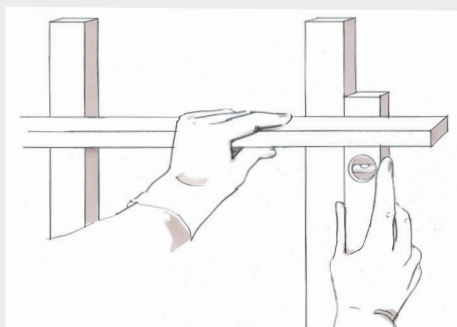

Typical ventilated batten for horizontal or vertical mounting

### USING ADHESIVES

- When fixing the panels with adhesive, we recommend using metal battens
- Both SIKA and Bostik have developed adhesive systems that can be used with STENI façade panels
- See FS400 for more information on using adhesives

### INSTALLATION WITH OPEN JOINTS



EPDM foil must cover the entire wooden batten

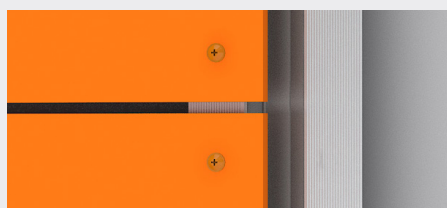

EPDM foil is optional on metal battens

**JOINT OPENINGS:**  
The façade panels are usually installed using 5 mm horizontal and vertical joints.

## Accessories

STENI supplies accessories that must be used during installation to meet product certificate requirements, type approvals and for the product warranty terms to apply

### EPDM FOIL



Widths	95 mm / 120 mm
Length per roll	25 m
Colours	White, black, grey
Used for installations using wooden battens.	

### POP RIVETS

[not stocked]



Dimensions	4.8 x 12/14/16 mm, head 9 mm
Material	Stainless steel A4 - ISO 3508
Coating	Polyester powder coating on the head
Pilot holes	Ø 5.5 mm in panels / Ø 4.8 mm in battens

### SCREWS

Wood screw

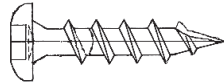

Screw size	4.0 x 28 mm og 4.0 x 33 mm
Material	Stainless steel A4 - ISO 3506
Coating	Polyester powder coating on the screw head
Bit type	Torx T20

Self-drilling metal screw

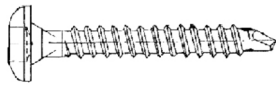

Screw size	4.2 x 25 mm
Material	Stainless steel A4 - ISO 3506
Coating	Polyester powder coating on the screw head
Bit type	Torx T20

Penetrating metal screw [not self-drilling]

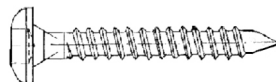

Screw size	4.5 x 25 mm
Material	Stainless steel A4 - ISO 3506
Max thickness	2 mm aluminium / 1 mm steel
Coating	Polyester powder coating on the screw head
Bit type	Torx T20

STENI also supplies accessories that will simplify the installation and ensure a good finish.

### PROFILES

#### STENI CORNER AND JOINT PROFILES

Dimensions	See product catalogue
Length	3 m
Colours	White, black, natural [anodised]. Other colours available on request
Material	Aluminium

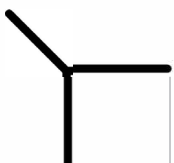

Corner profile  
CP 15-13

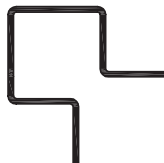

Corner profile  
CP 15-18-33

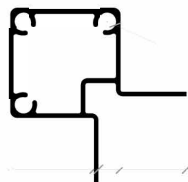

Corner profile  
CP 15-25-40



Joint profile  
FP 6-30



Joint profile  
HFP 7-30



Joint profile  
HP 7-30

## Accessories

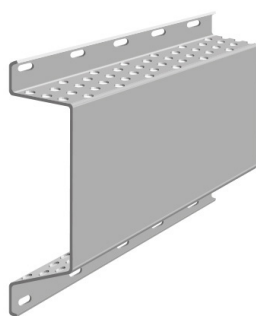

**COMING 2019**

### STENI VFL VENTILATED FAÇADE BATTEN

Dimensions	25 x 70/100 mm (h x w)
Thickness	0.7 and 1.0 mm
Length	3 mm
Colours	Grey and black
Material	Steel, corrosion class C5



## CUTTING DISCS

### DIAMOND CUTTING DISC FOR STENI NATURE

Diameter	Ø 125 mm, hole 22.2 mm
Liner bushings	-
Thickness	2 mm
Speed	max 13,300 RPM

### DIAMOND CUTTING DISC FOR STENI COLOUR AND VISION

Diameter	Ø 150 mm, hole 30 mm
Liner bushings	25.4 mm, 22.2 mm, 20 mm
Thickness	2.6 mm
Speed	max 10,000 RPM

## DRILL BITS



### STENI DRILL BITS FOR PILOT HOLES

Diameter	Ø 5.5 mm / Ø 6,0 mm
Type	Multi-construction (wood, metal, concrete)

STENI L and U-elements are available for both STENI Colour and STENI Nature. You can find sizes and our selection in the product catalogue.

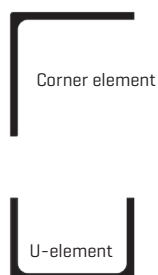

Corner element

U-element

### THE MOLOTOW EDGE PAINT MARKER WORKS ON ALL TYPES OF STENI PANELS

Tip	15 mm felt tip
Quantity	20 ml (covers approx. 100 running metres of edge)
Colour	NCS 8505-Y80R (dark colour)

Refill (200 ml) and extra tips can be purchased separately

## JIGSAW BLADES



### DIAMOND BLADE WORKS ON ALL TYPES OF STENI PANELS

Length	100 mm
Shank	Fits all known brands

## TYPICAL AREAS OF USE FOR ELEMENTS

- Terminations on outside corners
- Cladding of columns and coverings
- Window/door splays
- Transition between wall and ceiling



You can find a complete selection and descriptions in the current product catalogue. In the case of discrepancies in the information, the product catalogue always takes precedence.

## MOUNTING ON WOODEN BATTENS

Wooden battens can be in white or impregnated wood (max RF 15–20%). The recommended maximum batten thickness is 28 mm and they should be mounted at centre-to-centre distance (CC) of max 600 mm. The battens should have a width of at least 45 mm under the panels and at least 70 mm at the joints. Other widths and distances may be specified under the different installation types.

Before mounting the panels, the batten must be covered with STENI EPDM foil, which is attached using a staple gun. The EPDM foil should be wider than the batten and fixed so that the entire batten is covered. A 10–20 mm overlap is recommended on each side. This is to prevent water from entering the wall through the battens.

STENI wood screws should be used for screw mounting. These have been tested and optimised for our products and will ensure a good result.

It is important to position the screw in the centre of the hole when you install the panels. The tightening torque should be such that the screw head is screwed **up to** panel. Do not use excessive torque as this may reduce the screw pull-out value and damage the surface of the panel around the hole. Do not countersink the screw.

Do not use EPDM foil when using adhesive systems. Follow the adhesive manufacturer's recommendations. STENI recommends using metal battens for adhesive systems. See FS400 for more information

## BATTEN DISTANCES – WOOD AND METAL

The batten dimensions in the figure indicate the recommended minimum dimensions for wooden battens. The figure shows the standard batten distance for both wooden and metal battens. Standard batten distance applies unless otherwise specified.

For ceiling installations and the like, we recommend a batten distance of max. 400 mm.

When mounting on horizontal battens, we recommend using the FP 6–30 joint profile in the vertical joints to prevent water from penetrating the panels.

When mounting on horizontal wooden battens, cross-battening is necessary to ensure adequate ventilation. There are ventilated metal battens that provide adequate ventilation for horizontal mounting without cross-battening.

Horizontal battens should be mounted at a distance of 300–600 mm. [see figure]

Large panels mounted vertically should be mounted with a short

distance between the battens for a more aesthetic result.

Battens must be fitted to achieve a minimum air gap of 40–50 cm<sup>2</sup> per running metre at all horizontal terminations [for more information about ventilation and two-stage sealing, see the last page].

For mounting on tall buildings (over 10 m), wind loads may be important in determining the batten distance. STENI has created tables and formulas that can be used to determine the correct batten distance based on the calculated dimensioning wind load [see last page].

When using adhesives, only vertically mounted battens are permitted.

At panel joints, battens must be a minimum of 95 mm wide, see also FS400

For the wind load capacity of the adhesive system, please refer to the adhesive manufacturer.

### VERTICAL BATTENS

– standard batten distance for wooden and metal battens [horizontal cross-section]

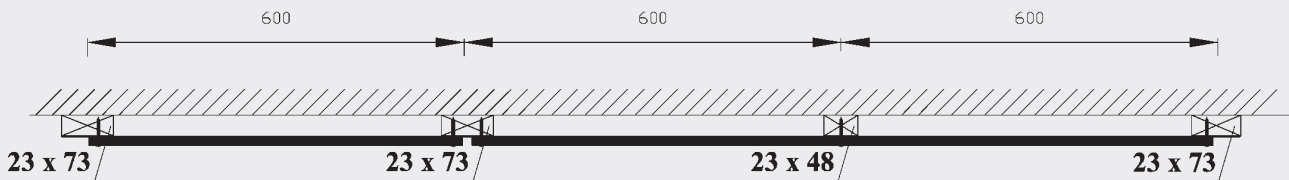

### HORIZONTAL BATTENS

– standard batten distance for wooden and metal battens [vertical cross-section]

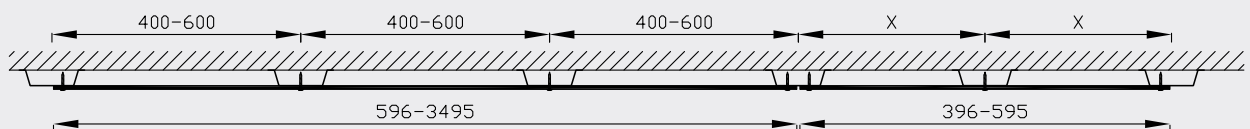

Note that with horizontal battens, you must have at least one centre batten for panel widths from 396 mm and upwards. Panel widths up to 395 mm can be mounted without a centre batten (under the edges only).



## Mounting on metal battens

In buildings with more than four storeys, battens of non-combustible material must normally be used. Metal battens are available in several materials and designs. The most common materials are steel or aluminium. The battens should be mounted with a centre-to-centre distance (CC) distance of max 600 mm. Other distances may be specified under the various installation types.

To avoid water penetration when mounting with open joints, the metal profiles should be attached to the rear wall structure with screws and rubber washers. Further protection of the joint is not necessary. When joining vertical metal profiles, use STENI EPDM foil to avoid water penetration. Alternatively, a joint profile (sliding sleeve) can be used.

The metal profiles are joined with a minimum of 5 mm gap between the profiles to allow for temperature expansion. The greatest recommended profile length is 3 m.

The batten and the panel will have different temperature expansion. To avoid unnecessary strain on the fixing points, we recommend adjusting the length of the battens to length of the panel where possible [see figure]. For panels over 3 m, you should use a short length of batten for the part of the panel beyond 3 m, and start with a new batten for the next panel. The short length of batten should be mounted so that it can move with the panel to which it is attached.

When using horizontal ventilated battens, we recommend using a

STENI joint profile in the vertical panel joints. This prevents water intrusion and helps to stiffen the panel edge.

Do not cut metal profiles with tools that generate heat (angle grinder etc.) as this may damage the corrosion protection in and around the cut.

STENI metal screws should be used for screw mounting. These have been tested and optimised for our products and will ensure a good result. For profiles with a thickness of up to 2 mm (Aluminium) and 1 mm (Steel), we recommend our penetrating metal screw (not self-drilling). The screw must be fastened in one continuous motion. Stopping and starting while fastening the screw could cause the screw head to become overloaded.

For thicker profiles, we recommend our self-drilling metal screw.

It is important to position the screw in the centre of the hole when you install the panels. The tightening torque should be such that the screw head is screwed up to panel. Do not use excessive torque as this may reduce the screw pull-out value and damage the surface of the panel around the hole. Do not countersink the screw.

Pop rivets can be used as an alternative to screws. Pre-drill the battens with a  $\varnothing$  4.8 mm drill bit. Pre-drill the panel a  $\varnothing$  5.5 mm drill bit.

When using adhesive systems, follow the recommendations of the adhesive manufacturer. See FS400 for more information.

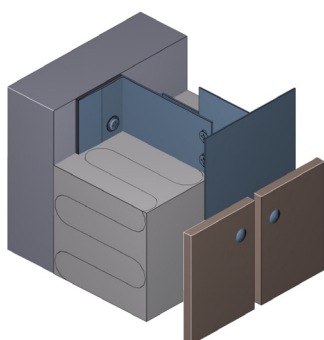

Typical installation with a batten system customised for exterior post-insulation

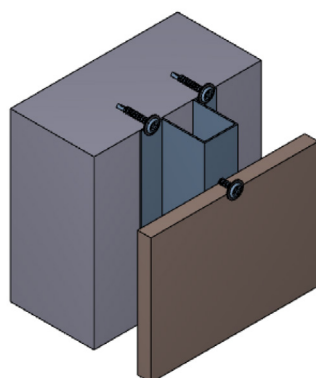

Typical installation with a hat profile under the panel

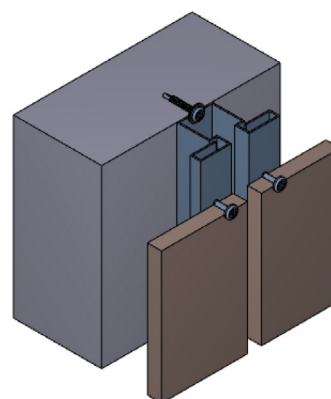

Typical installation with a hat profile at panel joints

### RECOMMENDED SOLUTIONS

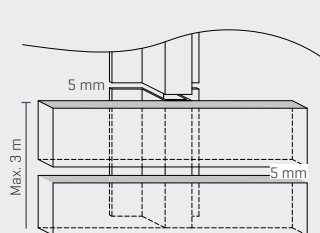

The battens should be adapted to the panel length. One or more panels can be mounted on the same batten (max 3 m). Remember to leave a 5 mm joint between the panels and a 5 mm joint between batten profiles.

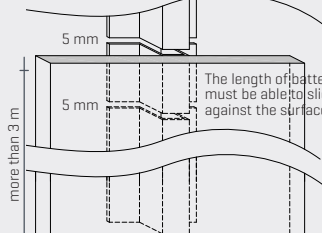
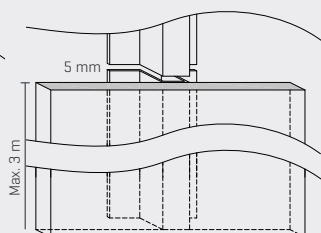

For panels over 3 m, use an extra length of batten to fit the panel. The length of batten must be able to move together with the panel (slide against the surface).

### NOT RECOMMENDED SOLUTION

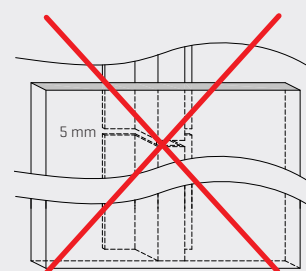

The panels should not be mounted over a batten joint. Different temperature expansion can cause heavy strain on fixing points.

# FS100 FLAT INSTALLATION WITH MECHANICAL FIXING

## MOUNTING OF STENI COLOUR, STENI VISION AND STENI NATURE

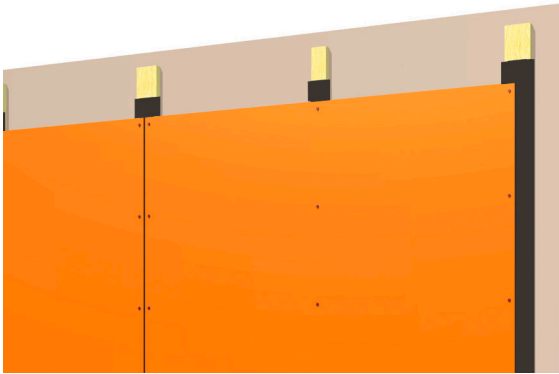

Vertical mounting  
EPDM foil must cover the entire wooden batten.

### FIXING:

The distance between the fixing points along the side edges and the centre should be max 300 mm. Use standard distance between battens.

For ceiling installations, etc. we recommend a batten distance of max. 400 mm.



Horizontal mounting  
EPDM foil is optional on metal battens.

### JOINT OPENINGS:

The façade panels are usually installed using 5 mm horizontal and vertical joints. When using joint profiles, you need 8–10 mm between the panels.

Use a spacer block. The panels must never be installed “butt-in-butt”.

### FIXING MATERIALS:

The façade panels are installed using STENI standard screws. Use a 4.0 x 28 mm wood screw or a metal screw of the correct size based on the thickness of the material.

When mounting on metal battens, pop rivets can also be used.

# FS200 NARROW PANELS INSTALLED AS BEVEL SIDING

## GENERAL INFORMATION

For installations following FS200, you must use vertical battens. We recommend that you start with a narrow strip of panelling at the base to get the correct angle for the bottom panel (see figure).

Screw type and dimension depend on the width of the panels and the batten material (see ill. on the following page).

When using metal battens, pop rivets can also be used. It may be necessary to use a longer rivet to pass through 2 panels (see figure). FS200 installations are not recommended for panel widths greater than 395 mm.

We recommend that you use the STENI corner element or our corner profile CP 15-25-40 as a finish on the outside corners.

For STENI Colour and Steni Vision, use standard batten distances. For Steni Nature, special rules apply (see next page).

The panels should always be fitted with a vertical joint opening of 5 mm. This also applies to the profile edge and other fixed installations.

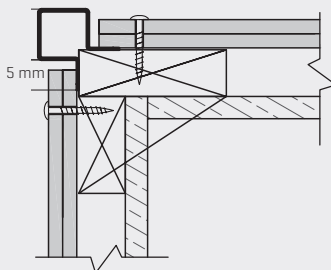

Exterior corner with corner profile CP-15-25-40

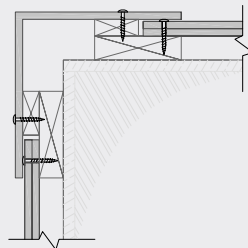

Exterior corner with corner element

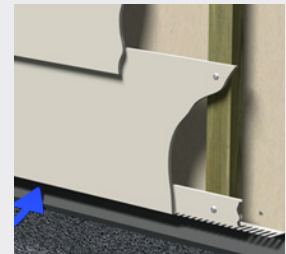

Start with a narrow strip of panelling at the base.

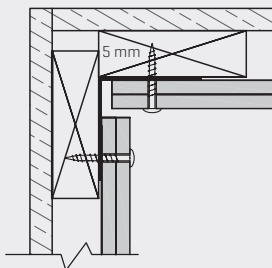

Inside corner with angle bracket

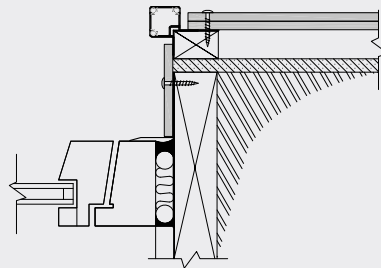

Edge along windows with corner profile CP-15-25-40



FS 200 with corner element

# FS200

NARROW PANELS INSTALLED AS BEVEL SIDING

PANEL HEIGHT: 196 MM



#### FIXING MATERIALS:

The façade panels are installed using STENI standard screws.

Use a 4.0 x 28 mm wood screw or a metal screw of the correct size based on the thickness of the material.

When using metal battens, pop rivets can also be used.

PANEL HEIGHT: 200 MM



#### FIXING MATERIALS:

The façade panels are installed using STENI standard screws.

Use a 4.0 x 33 mm wood screw or a metal screw of the correct size based on the thickness of the material.

When using metal battens, pop rivets can also be used.

The length of the pop rivets must be appropriate for the thickness of the material.

## SPECIAL FOR STENI NATURE INSTALLATIONS

Batten distance max. 450 mm [for 900 mm modules] and max. 400 mm [for 1,200 mm modules]

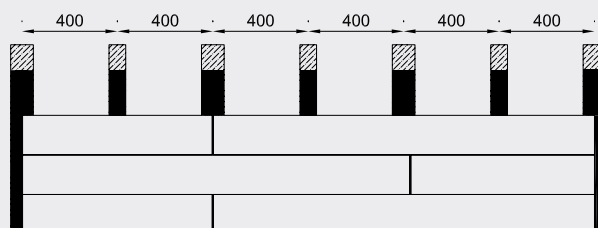

Batten distance for 1,200 mm module [front view]

## GENERAL FIXING INFORMATION

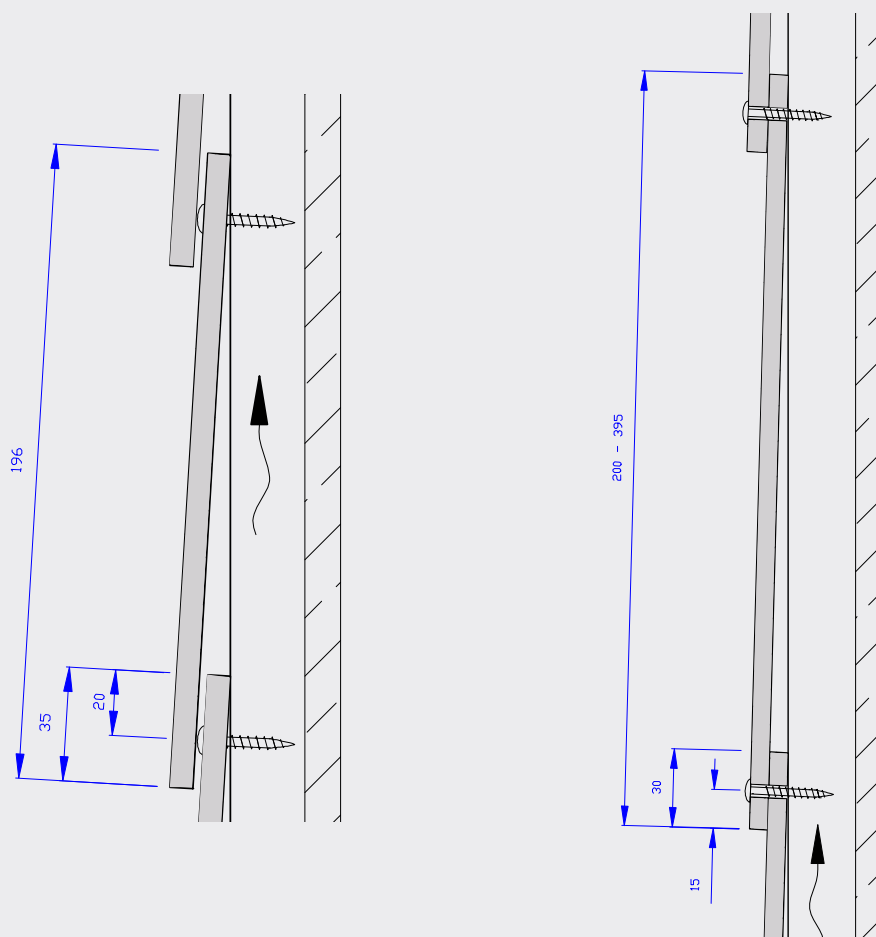

# FS400 FLAT INSTALLATION WITH ADHESIVE

## STENI COLOUR AND STENI VISION

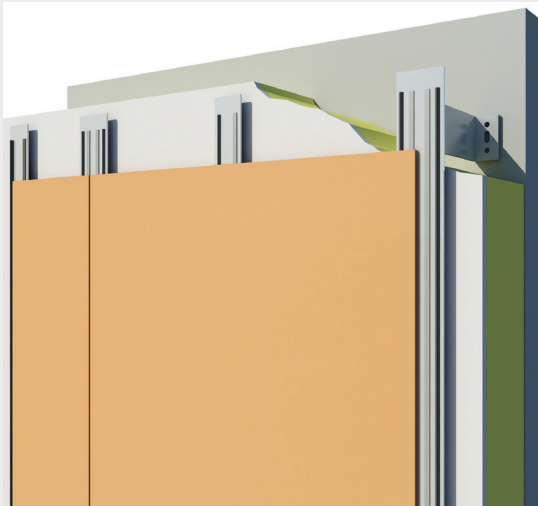

We recommend using metal battens when using adhesives

- Batten distance max c/c 600 mm. When installed on ceilings or similar, we recommend c/c 400 mm. We recommend using metal battens for best results.
- If wooden battens are used, the moisture content must not exceed 18% RH.
- Metal battens must be corrosion-proof. Recommended corrosion class is C5.
- When using adhesives, vertical battens must be used.
- If you are using wooden battens, we recommend planed spruce
- Minimum batten width at panel joints is 95 mm
- Minimum batten width in fields or terminations is 45 mm
- Some adhesive systems may have limitations for the size of the panels.
- Check the manufacturer's instructions.
- For buildings with more than four storeys, there may be requirements for mechanical fixing. Check the local building rules in your area [in Norway: VTEK [guidelines for technical regulations]]

- The battens must be clean, dry and free of dust, grease and /or oil before applying primer [3]. Primer can be applied to the batten before or after installation.
- Avoid applying any adhesive system components and installation during rainy weather or days of high humidity [fog/mist].
- Avoid moisture condensation on the surfaces with adhesive. The surface temperature of the surfaces where adhesives will be used must be min. 3 °C higher than the dew point.
- The correct working temperature is between +5 °C and +30 °C.
- The adhesive system consists of the following general components [type and designation are dependent on the manufacturer. See the adhesive manufacturer's instructions.]

### CLEANER

Cleaner is used to clean the STENI panel where tape [4] and the bead of adhesive [3] are applied. Clean an area of 10–15 cm along the entire length of the panel. Allow the panel to dry after application.

### PRIMER

Primer is used to prime the batten before applying the bead of adhesive [3] and double sided foam tape [4]. The primer must be allowed to dry before applying the adhesive/tape. The correct primer depends on the material [see the adhesive manufacturer's instructions]

### ELASTIC ADHESIVE

The adhesive is applied to the batten in a continuous bead. To ensure the correct amount of adhesive, use the supplied nozzle. Unless otherwise indicated, apply the bead of adhesive as a triangle, approx. 10 mm wide and 10 mm high. Make sure there are no air bubbles in the adhesive.

Allow a distance of min. 5 mm between beads of adhesive [3] and double sided tape [4]

### DOUBLE-SIDED FOAM TAPE

- Used to hold the panel in place while the adhesive [3] cures. We recommended that you apply the tape before applying the adhesive.
- When mounting the panel, place it in the correct position by pressing it into the bead of adhesive [3] but not into the tape [4].
- This allows you to fine-tune the position of the panel. The panel is fixed in place by pressing it against the double sided tape [4].
- The panel can no longer be adjusted and is mounted when it adheres to the tape along the entire length of the tape.

## OPEN JOINTS

The façade panels are normally mounted both horizontally and vertically with an open joint of 5 mm. When using joint profiles, you need 8–10 mm between the panels. The panels must never be installed “butt-in-butt”.

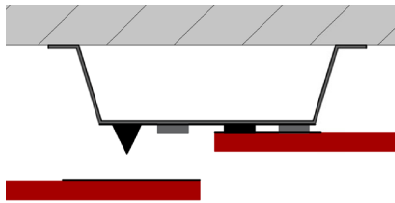

At the panel joint  
Min. width of batten is 100 mm

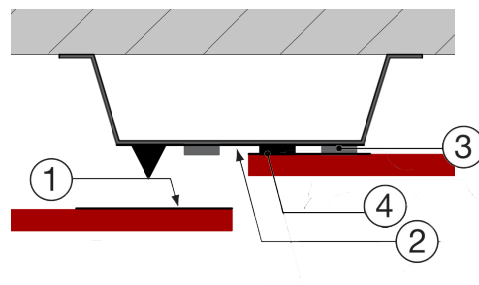

- 1: Cleaner
- 2: Primer
- 3: Elastic adhesive
- 4: Double-sided foam tape

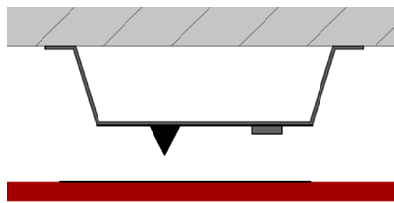

At the centre  
Min. width of batten is 70 mm

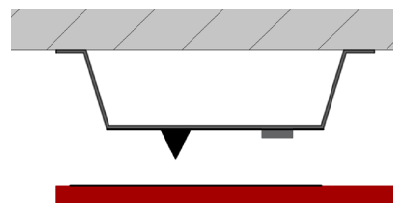

At terminations  
Min. width of batten is 70 mm



For façades using an adhesive system, refer to the adhesive manufacturer's instructions. Both Sika and Bostik have a special guide for STENI façade panels. If you use products from other adhesive manufacturers, the adhesive system must be tested and approved for the STENI panels where adhesives will be used.



# INSTALLATION WITH PROFILES

## INSTALLATIONS USING CORNER PROFILES

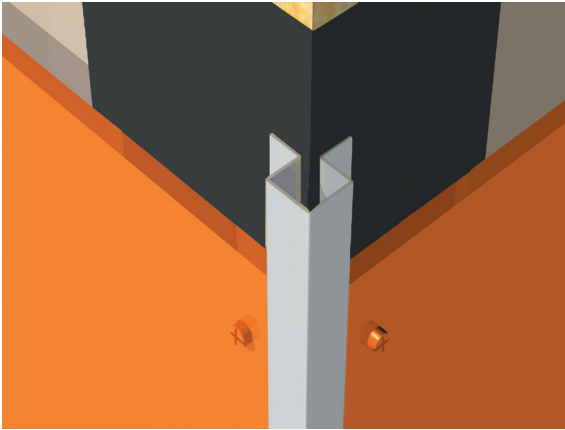

The EPDM foil must cover the entire wooden batten.

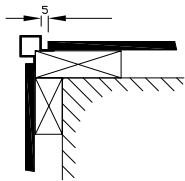

Corner with corner profile

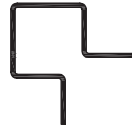

CP 15-18-33

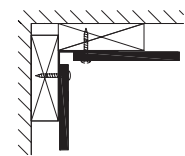

Inside corner

The profile is fixed by squeezing it between the panel and the batten.

We recommend a min. distance of 5 mm between the panel edge and the corner profile and a min. distance of 3 mm between the panel edge and the joint profile in the joint.

Remember to mount the profiles with a minimum of 5 mm gap between each length. [Thermal expansion]



CP 15-13

## INSTALLATIONS USING JOINT PROFILES

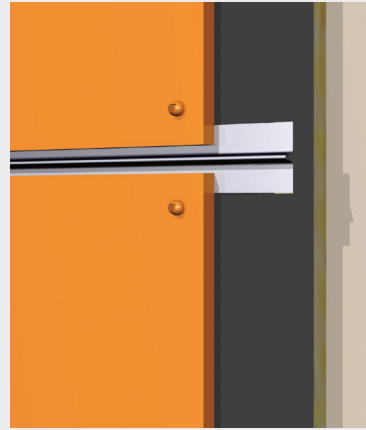

The EPDM foil must cover the entire wooden batten.

When using joint profiles, you need 8–10 mm between the panels.

Use a spacer block.

1. Vertical/horizontal profile: FP 6-30
2. Horizontal profile: HFP 7-30
3. Horizontal profile: HP 7-30

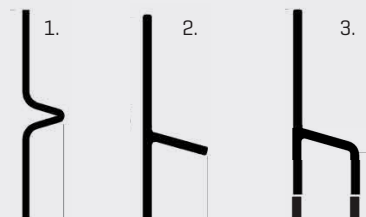

Corner and joint profiles can also be used with metal battens.



# INSTALLATION WITH ELEMENTS

## INSTALLATIONS USING CORNER ELEMENTS OR U-ELEMENTS

### CORNER ELEMENT:

At corners, we recommend corner elements or corner profiles to achieve straight and attractive corners.

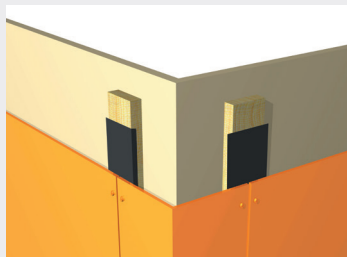

The EPDM must cover the entire wooden batten.

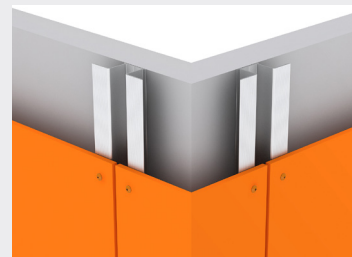

Corner elements on metal battens

The figures show battening principles for U-elements.  
The wings on the U-elements are battened in the same way as for L-elements.  
The bottom of the U-element is battened according to the figure

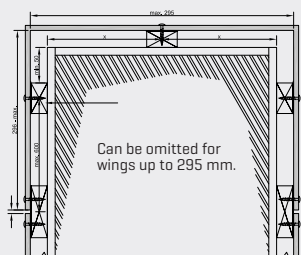

Bottom up to 295 mm.

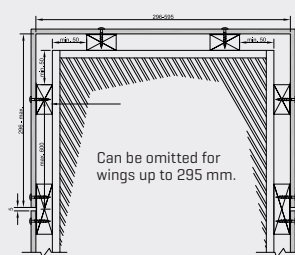

Bottom from 296 to 595 mm.

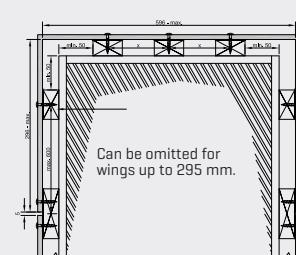

Bottom larger than 595 mm.

### BATTENING AND FIXING:

For elements with wings up to 295 mm, it is enough to place a batten along each of the free edges. For elements with larger wing dimensions, you must use at least one batten against the corner of each side.

For U-elements with a bottom panel of up to 295 mm, a batten is placed in the centre of the bottom panel. If the bottom panel is up to 595 mm, use two battens for each corner. If the bottom is wider than this, use two battens + centre batten.

Due to manufacturing tolerances on the element angle, the battens should not be placed all the way out at the corner. We recommend a distance of at least 50 mm between the corner and the batten.

Maximum batten distance is 600 mm. The distance between the fixing points along the batten must not exceed 300 mm.

See figures.

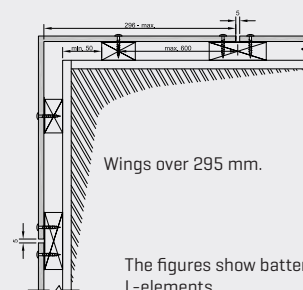

Wings over 295 mm.

The figures show battening principles for L-elements.

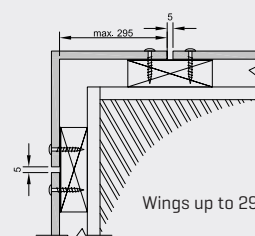

Wings up to 295 mm.

## Operation and Maintenance

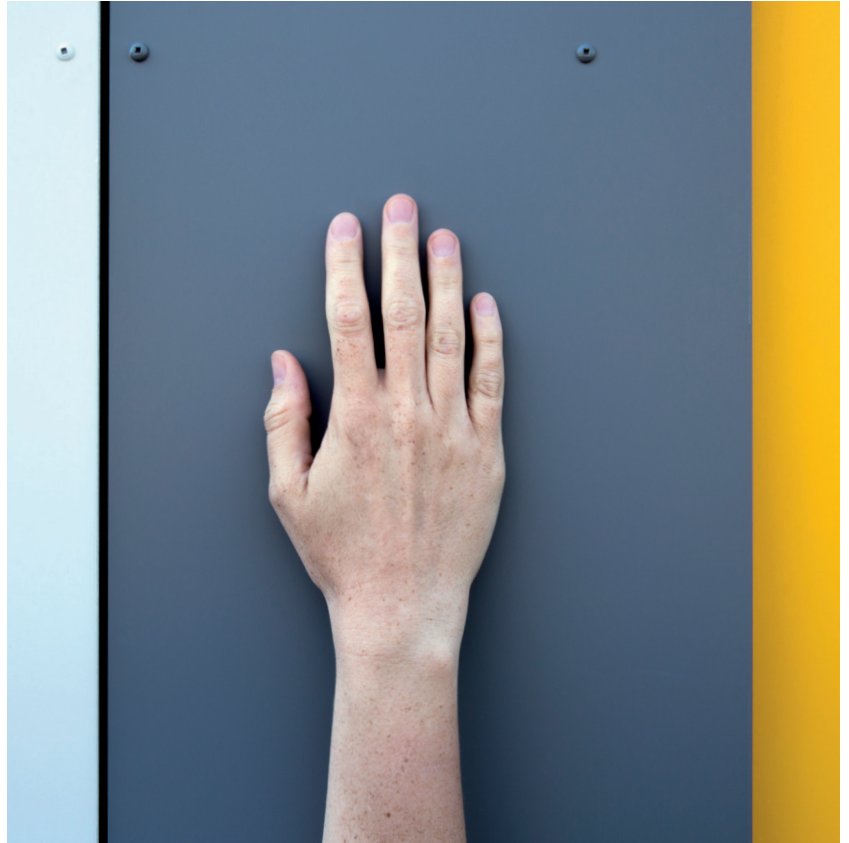

### CLEANING

#### CHOOSING A CLEANING AGENT

All STENI panels can be cleaned with most cleaning agents on the market intended for use on buildings [e.g. house wash cleaner].

Choose a cleaning product based on what you want to wash off. Follow the usage instructions for the cleaning product carefully. If you are uncertain, we recommend performing a test in a discrete location, or contact a professional cleaning company. STENI Nature and STENI Terra can be primed and impregnated to make the surface easier to keep clean.

#### HIGH-PRESSURE WASHING

All STENI panels can be cleaned with a high-pressure washer up to 100 bar and temperatures up to 80 °C. Hold the nozzle should at least 20–30 cm from the surface. High-pressure washing at high temperatures produces good results, saves the environment and is preferable to excessive use of chemicals. When using high-pressure washers on STENI Nature and STENI Terra, there is always a risk that the surface stone could loosen. Exercise caution.

#### AFTER THE INSTALLATION

Wipe away drilling and cutting dust with a damp cloth containing an alkaline cleaning agent. All labels etc. should be removed immediately after installation. Remove any residual adhesive with a suitable cleaning agent.

#### CUTTING/DRILLING DUST

Always use tools with dust extraction systems when cutting and drilling STENI panels. Dust that is not sucked can be easily removed with compressed air and a damp microfibre cloth and an alkaline cleaning agent.

#### PAINT, GRAFFITI, VARNISH, STAIN ETC.

For proper removal of paint, graffiti, etc. it is important to determine what type of paint products have been used and choose cleaning agents accordingly. Improper use or unsuitable products may cause the paint to penetrate deeper into the panel.

Always contact a professional cleaning company before attempting to remove paint products [see [steni.com](http://steni.com) for video showing graffiti removal].

#### OIL, GREASE, SOOT ETC.

Use aromatic degreasing agents or similar product designed for use on painted surfaces [cars etc.]

Follow the instructions carefully. Rinse the façade with a high-pressure washer, preferably in combination with hot water. Use plenty of water.

## Operation and Maintenance

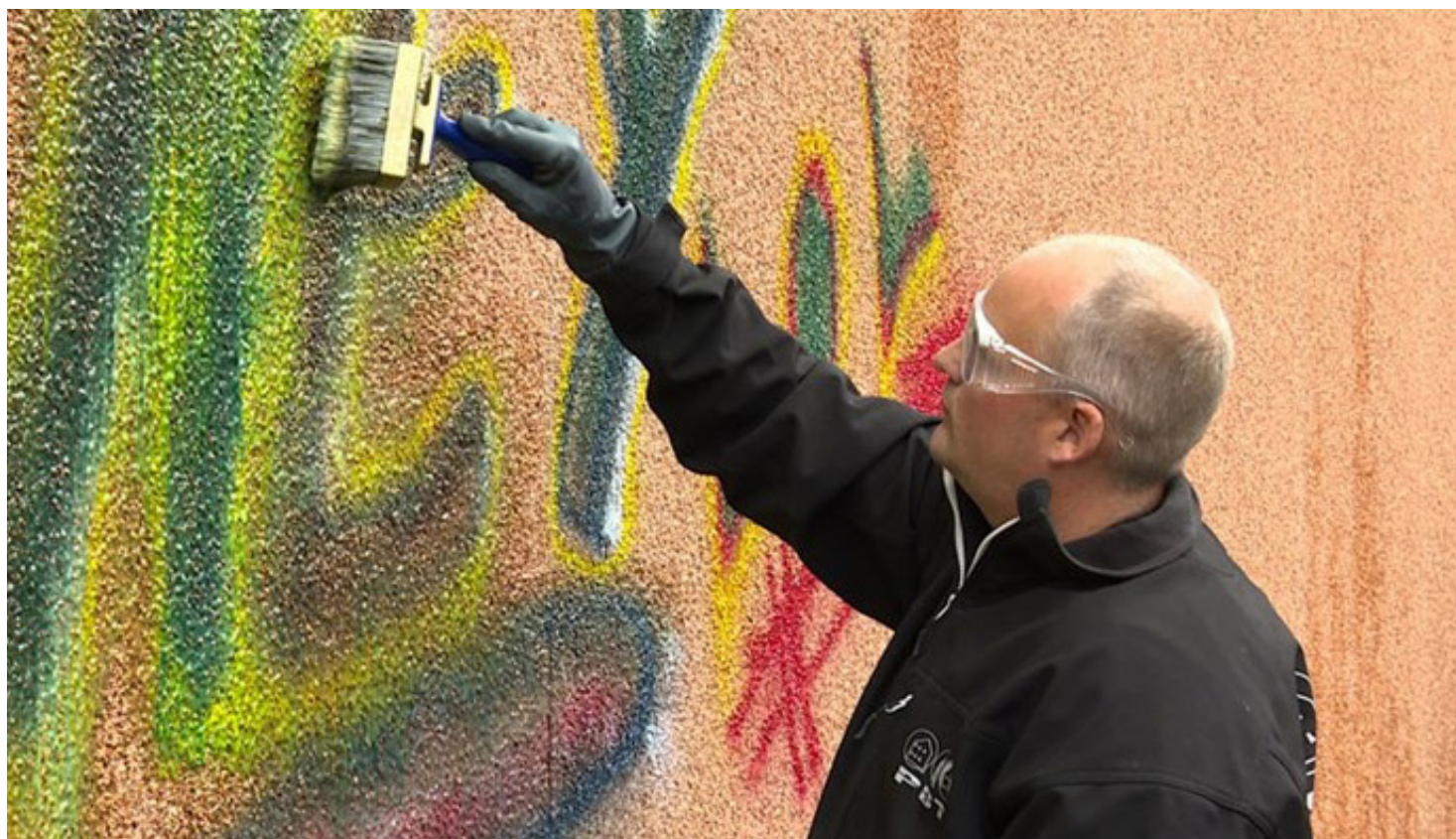

### ALGAE, MOSS, DIRT ETC.

Use an alkaline or pH-neutral cleaning agent intended for the task. Follow the usage instructions carefully. Rinse clean with a high-pressure washer. Use plenty of water.

### DISINFECTION

STENI Colour and STENI Vision are suitable as surfaces that require regular disinfection [food industry, operating rooms etc.]

### ACIDIC CLEANING AGENTS

STENI Nature and STENI Terra contain limestone, which can become discoloured if you use acidic cleaning agents.

## MAINTENANCE

Pollution, temperature fluctuations, weather and wind cause wear and tear on the façade. STENI façade panels and façade systems require an annual visual inspection to ensure optimum lifespan and a stable façade with a beautiful, exclusive appearance year after year.

The warranty provisions require regular and necessary maintenance of the façade. You should check the following points annually to ensure you perform necessary maintenance:

- Check if the façade needs washing. The joints and areas around the ducts etc. are particularly exposed.
- Make sure the panels are intact and with no cracks/damage from impacts from vehicles, vandalism etc.
- Make sure the panels are properly attached and that the screws are not loosening.
- Ensure adequate ventilation of the façade is maintained and that the underlying structure is not suffering from moisture damage.

## Tips for safe planning and design

### INTRODUCTION

Design of the façade system must always be in accordance with applicable national and local regulations. Designers are responsible for selecting products and solutions that satisfy these requirements, both individually and as a complete system.

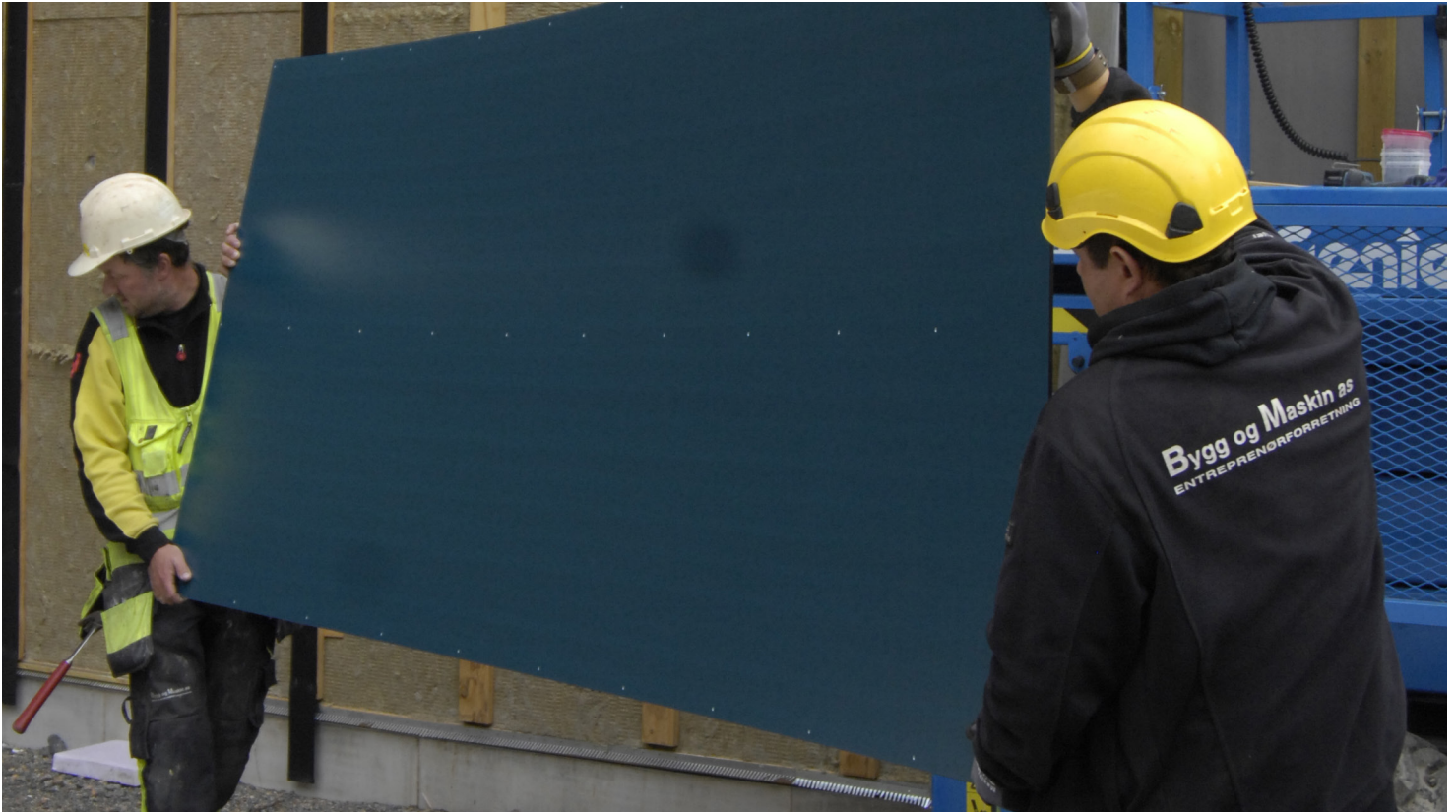

### CAPACITY CALCULATIONS

Pull-out values for various fixing materials in different materials

The table below indicates the dimensioned pull-out capacity for various fixing materials in different materials

Fixing material	Material			Dimensioned capacity [ $F_{Rd}$ ]		
Wood screw 4.2 x 28 mm	Wood C18			341 N		
Self-drilling metal screw 4.0 x 25 mm	0.7 mm steel	1.0 mm steel	2.0 mm aluminium	666 N	1,000 N	1,200 N
Self-drilling metal screw 4.5 x 25 mm	0.7 mm steel	1.0 mm steel	1.0 mm aluminium	777 N	1,250 N	972 N
Pop rivet 4.8 x 12/14/16 mm	0.7 mm steel	1.0 mm steel	1.0 mm aluminium	2500 N	2500 N	2500 N

**Table 1.** Pull-out values

### DIRECTION OF THE PANELS

For dark coloured STENI Colour panels, for aesthetic reasons, we recommend to mount the panels in the same direction [see arrows on the back of the panels]

## Tips for safe planning and design

### WIND LOADS

The following formula is used to calculate the dimensional wind load capacity for different panel dimensions:

$$q_{Rd} [N/m^2] = N_f \cdot F_{Rd}$$

where

$N_f$  is the number of fixing points per  $m^2$  [see table 2a/2b]

$F_{Rd}$  is the pull-out capacity [see table 1]

#### Calculation of the fixing point and batten distance

Wind load depends on the shape and height of the building, as well as the terrain surrounding the building

The dimensional wind load on the facade [  $q_{sd}$  ] can be calculated according to the rules in EN 1991-1-4.

The dimensioning criterion is:  $q_{Rd} \geq q_{sd}$

The required number of fixing points per  $m^2$  is thus as follows:  
 $N_f \geq q_{sd} / F_{Rd}$

Table 2a below shows the minimum number of fixing points per  $m^2$  for different panel widths and horizontal mounting.

Table 2b shows the minimum number of fixing points for vertical mounting. For both tables, vertical battens and standard drill patterns apply.

Table 3 shows the maximum allowed building height for different terrain types and reference wind speeds [  $V_b$  ]. The table applies when using wooden screws and  $N_f = 8.3$  screws/ $m^2$  [see table 2a]. Required capacity for a 100 m building in terrain type 0 and 26m/s is

The calculation is made according to the rules in EN 1991-1-4:2005/AC:2010 as well as Table C-10a in BFS 2013:10 EKS 9

$$q_{Rd(100,0,26)} = 3.7kN/m^2$$

ASSUMPTIONS:

wind load form factor:  $\mu = 1.4$

load factor in breaking limit:  $\psi_{11} = 1.5$

Panel thickness in mm	Number of fixing points per $m^2$ [ $N_f$ ]		
	Batten distance in mm		
	300	400	600
295-395	18.8	14.4	10.1
396-630	17.7	13.6	9.5
631-930	15.9	12.3	8.6
931-1,195	15.5	11.9	8.3

**Table 2a.** Number of fixing points for horizontal mounting

Panel thickness in mm	Number of fixing points per $m^2$ [ $N_f$ ]			
	Distance between screws in mm*		Distance between screws in mm**	
	240	300	240	300
295-395	23.1	18.8	***	***
396-595	15.3	12.5	23	18.7
596-930	***	***	14.7	11.9
931-1,195	***	***	11.4	9.33

**Table 2b.** Number of fixing points for vertical mounting

\*Battens along panel edge only \*\*Battens along the panel edge and in the middle

\*\*\*Not recommended

$V_b$ [m/s]	Maximum building height in meters in different terrain types				
	0	I	II	III	IV
21	-	-	-	-	-
22	100	-	-	-	-
23	80	100	100	-	-
24	47	60	95	-	-
25	30	40	65	100	-
26	19	26	45	95	100

**Table 3.** Permissible building height for different terrain types using wood screws and  $N_f = 8.3$  following table 2a

## Tips for safe planning and design



### FIRE

#### FIRE CLASSIFICATION

All STENI Colour, Nature and Vision panels are classified according to EN 13501 and achieve class B-s1, d0.

In addition, a number of large-scale fire tests have been carried out, ensuring that the products can also be used in tall buildings (over 8 storeys).

Tests have been performed in accordance with SP FIRE 105, NFPA 285 and ULC-S134. For a complete list of performed fire tests and ratings refer to our website [steni.com](http://steni.com).

#### BATTEN THICKNESS AND FIRE INSULATION

Batten thickness greater than 28 mm can lead to an increased risk of fire spreading in tall buildings due to the chimney effect. If the requirement for batten thickness exceeds this, we recommend the use of expanding fire retardant insulation or similar material placed horizontally in the air gap at each floor level. The material must be such that it seals the cavity behind the façade in the event of a fire, but does not prevent air flow through the façade under normal conditions. In this way, the drainage air gap is maintained while flames and flue gases will not spread through the cavity behind the climate screen.

## VENTILATED CLADDING WITH TWO-STAGE SEALING

### AIR GAP REQUIREMENTS

Adequate drainage and ventilation of the cavity behind the façades panels is important for preventing the underlying structure from becoming damp.

When mounting STENI panels with an open 5 mm joint, a 23 mm thick batten will achieve satisfactory ventilation. A corresponding air gap is also used for exterior post-insulation.

However, in areas with high levels of precipitation, additional protection against rainwater may be required. In such areas, we recommend using one of our joint profiles for a more impermeable climate screen. See also SINTEF Building and Infrastructure Design Guide 542.003

When using horizontal battens, we recommend using our VFL batten. It is perforated to ensure airflow behind the façade. The batten is also designed to prevent standing water in the perforations that could be directed towards the underlying structure.

When using horizontal battens, it is important to stop horizontal ventilation at the corners to prevent wind pressure from passing freely around the corners. Similarly, large façades should be divided into fields. When using horizontal battens, we recommend using the joint profiles in the vertical joints to prevent unnecessary water intrusion regardless of the amount of rainfall in the area.

For finishing along foundations, cornices, windows and doors, battens and fittings must be installed so that the air gap is not sealed. We recommend an air gap of minimum 40–50 cm<sup>2</sup> per running metre of facade at all horizontal terminations. [see figures below]

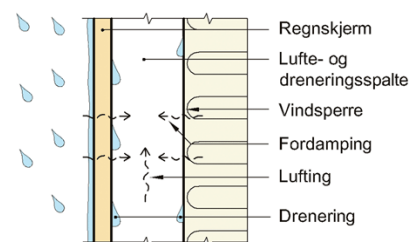

Two-stage sealing principle

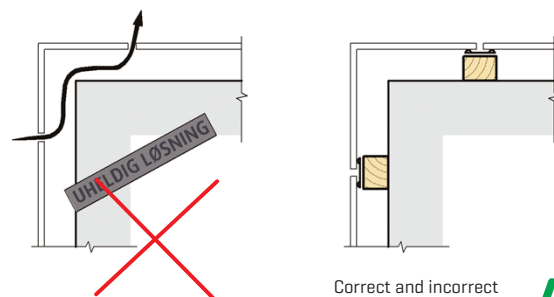

Correct and incorrect corner solution with horizontal battens (horizontal cross-section)

## Tips for safe planning and design

### DETAILS AND TERMINATIONS

#### MOUNTING AROUND WINDOWS AND DOORS

Various combinations of fittings, corner profiles and panel solutions are possible.

Vertical cross-section that shows the correct implementation to ensure ventilation along foundations, windows, doors and cornices.  
Min 40-50 cm<sup>2</sup>/m

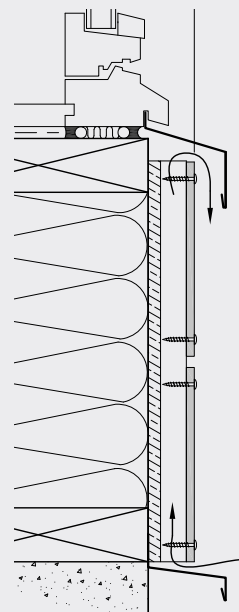
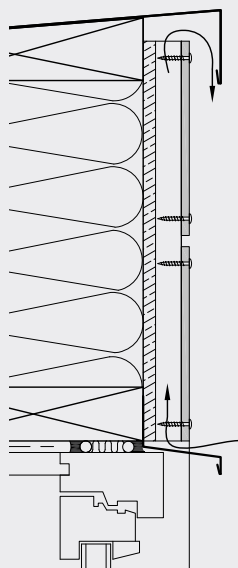

With panel fittings  
[horizontal cross-section]

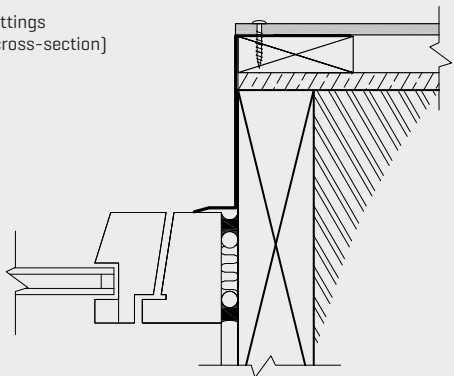

Corner element combined with fittings  
[horizontal cross-section]

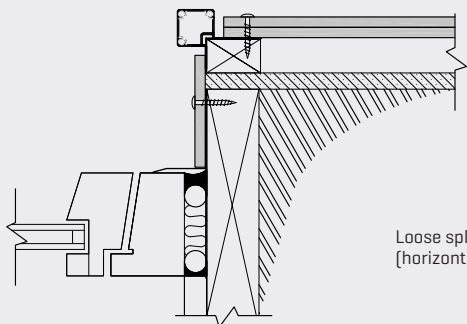
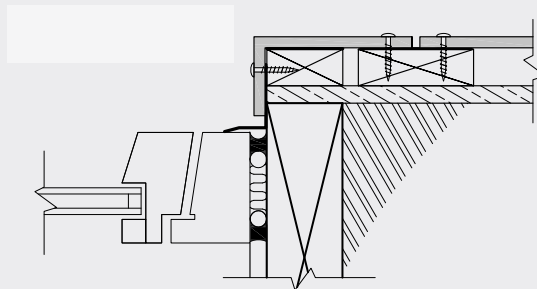

Loose splay panel with corner profile  
[horizontal cross-section]

**STENI AS**

Lågendalsveien 2633,  
NO-3277 Steinsholt,  
Norway  
P +47 33 15 56 00,  
E info@steni.com



- Sea of surfaces -

STENI's high-quality façade solutions will give your building a unique and enduring architectural expression. A sea of available surfaces, from colourful and smooth in different gloss levels, to surfaces of crushed stone in a variety of shades and grades – and printed surfaces so you can make your own custom designs. With STENI, you can design your building exactly the way you want it!

Since our establishment in 1965, we have delivered more than 48 million square metres of quality panels around the world.